



VECTOR



***broadband distribution node
GAMMA - PLUG-IN MODULES***

OFR 870-SCA

Single optical receiver module

PARAMETER	VALUE	COMMENT
Wavelength [nm]	1100 ÷ 1600	
Optical input power range [dBm]	-5 ÷ +2	
Bandwidth [MHz]	47 ÷ 870	
Equivalent input noise [pA/√Hz]	≤ 8	
Optical connector	SC/APC	Others on request
Optical power test point [V/mW]	1 ± 0,1	
RF level at the output of the module [dBμV]	78 ± 1	4,5% OMI/channel, 0dBm input optical power
Optical Power Indicator [dBm]	-5	Green - optical power > -5dBm Red - optical power < -5dBm
RF test point - directional [dB]	-20	Relative to module output signal

BLOCK DIAGRAM

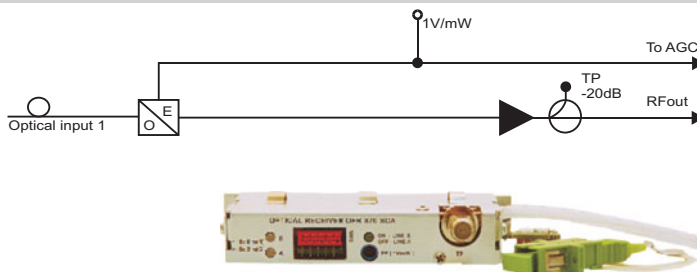

CNR vs. optical input power and OMI /channel

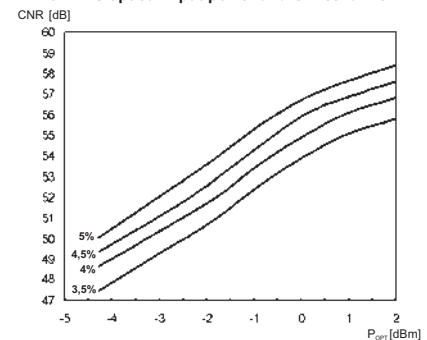

OSR 870-SCA

Redundant optical receiver module

PARAMETER	VALUE	COMMENT
Wavelength [nm]	1100 ÷ 1600	
Optical input power range [dBm]	-5 ÷ +2	
Bandwidth [MHz]	47 ÷ 870	
Equivalent input noise [pA/√Hz]	≤ 8	
Optical connector	SC/APC	Others on request
Optical power test point [V/mW]	1 ± 0,1	
RF level at the output of the module [dBμV]	78 ± 1	4,5% OMI/channel, 0dBm input optical power
Optical Power Indicator [dBm]	-5	Green - optical power > -5dBm Red - optical power < -5dBm
RF test point - directional [dB]	-20	Relative to module output signal

BLOCK DIAGRAM

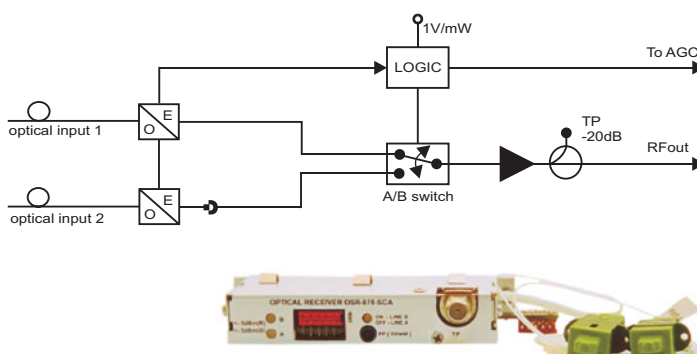

CNR vs. optical input power and OMI /channel

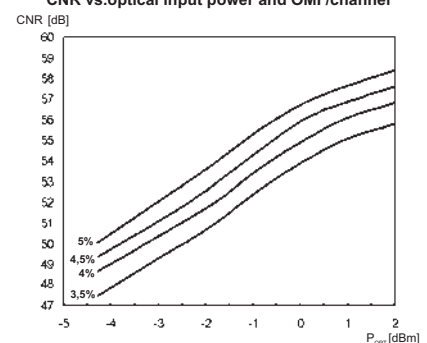

ORT F1310-SCA, ORT F1310-SCA/55/, ORT F1310-SCA/42/, ORT F1310-SCA/30/

FP 1310 nm optical transmitter module

PARAMETER	VALUE	COMMENT
Laser type	FP non-isolated	
Wavelength [nm]	1310 ± 40	
Optical output power [dBm]	0 ± 1	
Bandwidth [MHz] • ORT F1310-SCA • ORT F1310-SCA/55/ • ORT F1310-SCA/42/ • ORT F1310-SCA/30/	5 ÷ 65 5 ÷ 55 5 ÷ 42 5 ÷ 30	For internal RF input
Minimum input level for NPR > 30dB [dBμV/Hz] • ORT F1310-SCA • ORT F1310-SCA/55/ • ORT F1310-SCA/42/ • ORT F1310-SCA/30/	6 7 8 9	RF signal feeding the laser diode @ 25°C, 5dB passive optical loss, for: 60 MHz load 50 MHz load 37 MHz load 25 MHz load
Dynamic range for NPR > 30dB [dB]	>25	5dB optical loss
Optical connector	SC/APC	Others on request
Laser power status indicator [dBm]	-3	Green - optical power > -3dBm Red - optical power < -3dBm
RF test point - directional [dB]	-15	Relative to RF signal feeding the laser diode
Insertion loss for internal RF input [dB]	5	For 0dB pad and OLP module
Bandwidth [MHz]	5 ÷ 210	For external RF input - port 1
Insertion loss for external RF input [dB]	4	For 0dB pad
OMI variation over temperature [dB]	± 2	

BLOCK DIAGRAM

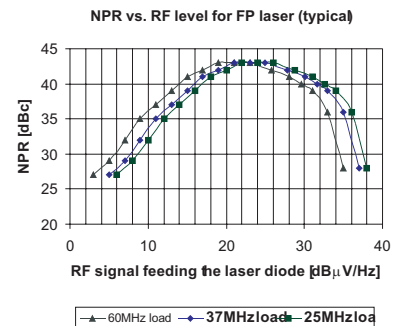
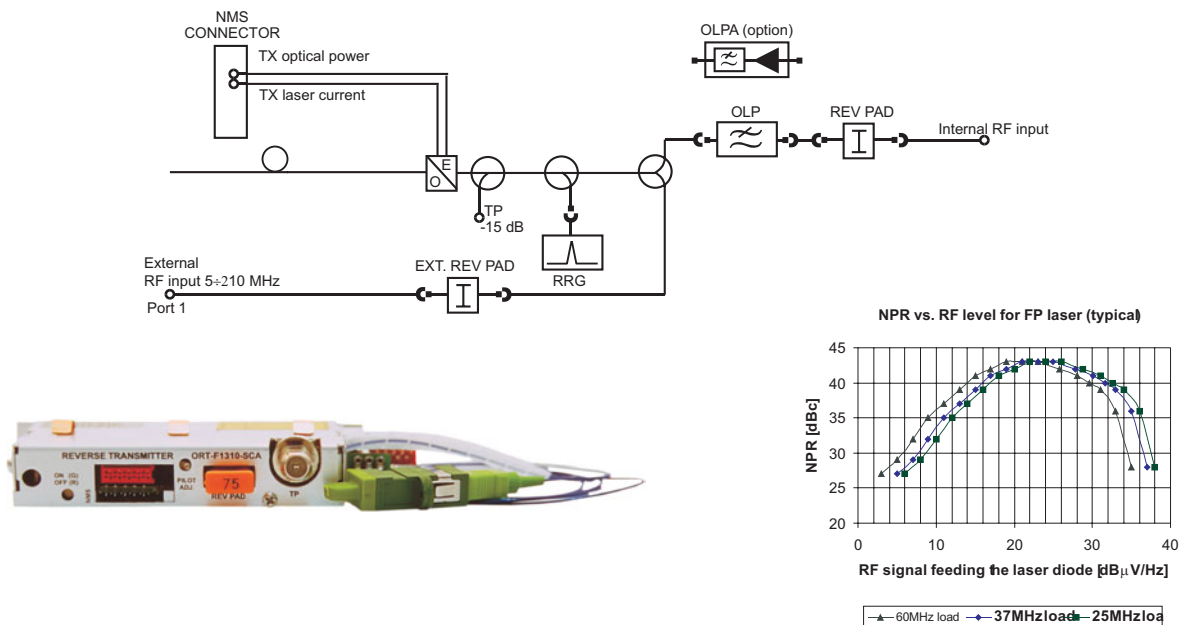

ORT 3D1310-SCA, ORT 3D1310-SCA/55/, ORT 3D1310-SCA/42/, ORT 3D1310-SCA/30/

DFB 1310 nm optical transmitter module

PARAMETER	VALUE	COMMENT
Laser type	DFB isolated	
Wavelength [nm]	1310 ± 20	
Optical output power [dBm]	3 ± 1	
Bandwidth [MHz] • ORT 3D1310-SCA • ORT 3D1310-SCA/55/ • ORT 3D1310-SCA/42/ • ORT 3D1310-SCA/30/	5 ÷ 65 5 ÷ 55 5 ÷ 42 5 ÷ 30	For internal RF input
Minimum input level for NPR > 35dB [dBμV/Hz] • ORT 3D1310-SCA • ORT 3D1310-SCA/55/ • ORT 3D1310-SCA/42/ • ORT 3D1310-SCA/30/	0 1 2 3	RF signal feeding the laser diode @ 25°C, 5dB passive optical loss, for: 60 MHz load 50 MHz load 37 MHz load 25 MHz load
Dynamic range for NPR > 35dB [dB]	>25	5dB optical loss
Optical connector	SC/APC	Others on request
Laser power status indicator [dBm]	0	Green - optical power > 0dBm Red - optical power < 0dBm
RF test point - directional [dB]	-15	Relative to RF signal feeding the laser diode
Insertion loss for internal RF input [dB]	5	For 0dB pad and OLP module
Bandwidth [MHz]	5 ÷ 210	For external RF input - port 1
Insertion loss for external RF input [dB]	4	For 0dB pad
OMI variation over temperature [dB]	± 2	
Temperature range [°C]	-40 ÷ +55	Optical node ambient temperature

BLOCK DIAGRAM

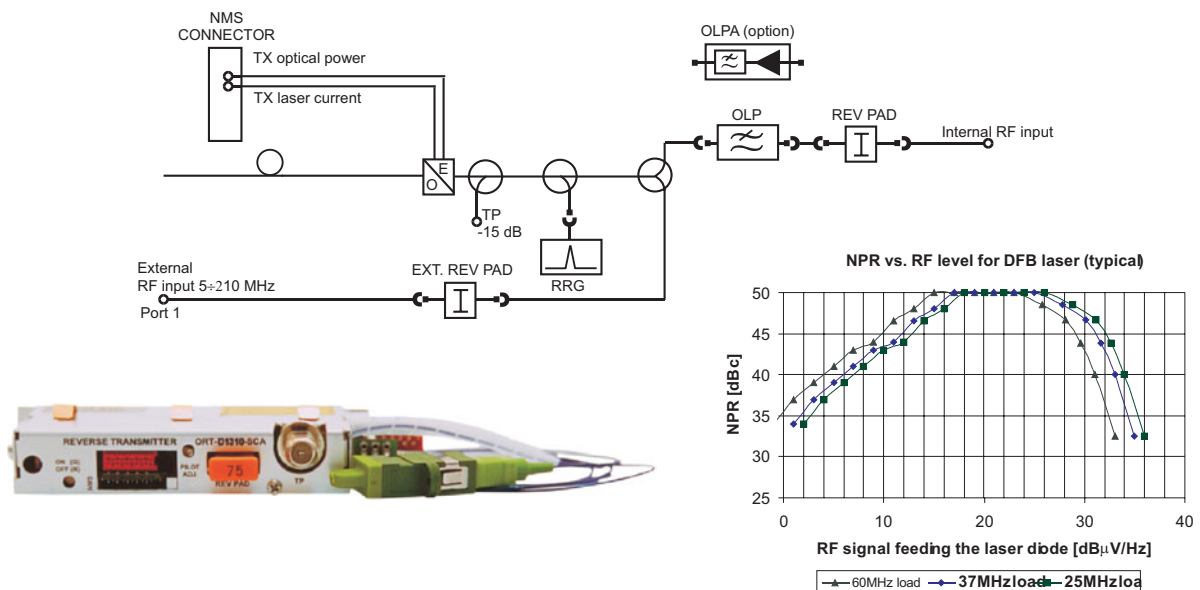

ORT D1550-SCA, ORT D1550-SCA/55/, ORT D1550-SCA/42/, ORT D1550/30/

DFB 1550 nm optical transmitter module

PARAMETER	VALUE	COMMENT
Laser type	DFB isolated	
Wavelength [nm]	1550 ± 20	
Optical output power [dBm]	3 ± 1	
Bandwidth [MHz] • ORT D1510-SCA • ORT D1510-SCA/42/ • ORT D1510-SCA/55/ • ORT D1510-SCA/30/	5 ÷ 65 5 ÷ 55 5 ÷ 42 5 ÷ 30	For internal RF input
Minimum input level for NPR > 35dB [dBμV/Hz] • ORT D1510-SCA • ORT D1510-SCA/42/ • ORT D1510-SCA/42/ • ORT D1510-SCA/30/	1 2 3 4	RF signal feeding the laser diode @ 25°C, 5dB passive optical loss, for: 60 MHz load 60 MHz load 37 MHz load 25 MHz load
Dynamic range for NPR > 30dB [dB]	>25	5dB optical loss, 60MHz load
Optical connector	SC/APC	Others on request
Laser power status indicator [dBm]	0	Green - optical power > 0dBm Red - optical power < 0dBm
RF test point - directional [dB]	-15	Relative to RF signal feeding the laser diode
Insertion loss for internal RF input [dB]	5	For 0dB pad and OLP module
Bandwidth [MHz]	5 ÷ 210	For external RF input - port 1
Insertion loss for external RF input [dB]	4	For 0dB pad
OMI variation over temperature [dB]	± 2	

BLOCK DIAGRAM

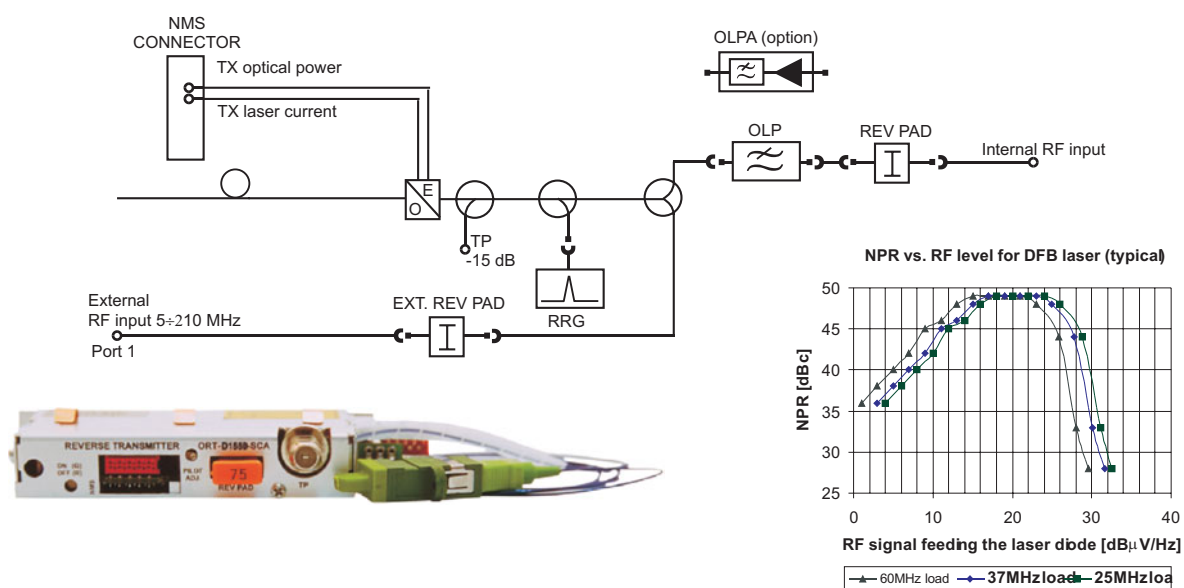

ORT DCXXX-SCA, ORT DCXXX-SCA/55/, ORT DCXXX-SCA/42/, ORT DCXXX/30/

DFB CWDM transmitter module
(XXXX = 1470, 1490, 1510, 1530, 1550, 1570, 1590, 1610 nm)

PARAMETER	VALUE	COMMENT
Laser type	DFB isolated	
Wavelength [nm]	XXXX ± 2	
Optical output power [dBm]	3 ± 1	
Bandwidth [MHz] • ORT DCXXX-SCA • ORT DCXXX-SCA/55/ • ORT DCXXX-SCA/42/ • ORT DCXXX-SCA/30/	5 ÷ 65 5 ÷ 55 5 ÷ 42 5 ÷ 30	For internal RF input
Minimum input level for NPR > 35dB [dBμV/Hz] • ORT DCXXX-SCA • ORT DCXXX-SCA/55/ • ORT DCXXX-SCA/42/ • ORT DCXXX-SCA/30/	1 2 3 4	RF signal feeding the laser diode @ 25°C, 5dB passive optical loss, for: 60 MHz load 50 MHz load 37 MHz load 25 MHz load
Dynamic range for NPR > 30dB [dB]	>25	5dB optical loss, 60MHz load
Optical connector	SC/APC	Others on request
Laser power status indicator [dBm]	0	Green - optical power > 0dBm Red - optical power < 0dBm
RF test point - directional [dB]	-15	Relative to RF signal feeding the laser diode
Insertion loss for internal RF input [dB]	5	For 0dB pad and OLP module
Bandwidth [MHz]	5 ÷ 210	For external RF input - port 1
Insertion loss for external RF input [dB]	4	For 0dB pad
OMI variation over temperature [dB]	± 2	

BLOCK DIAGRAM

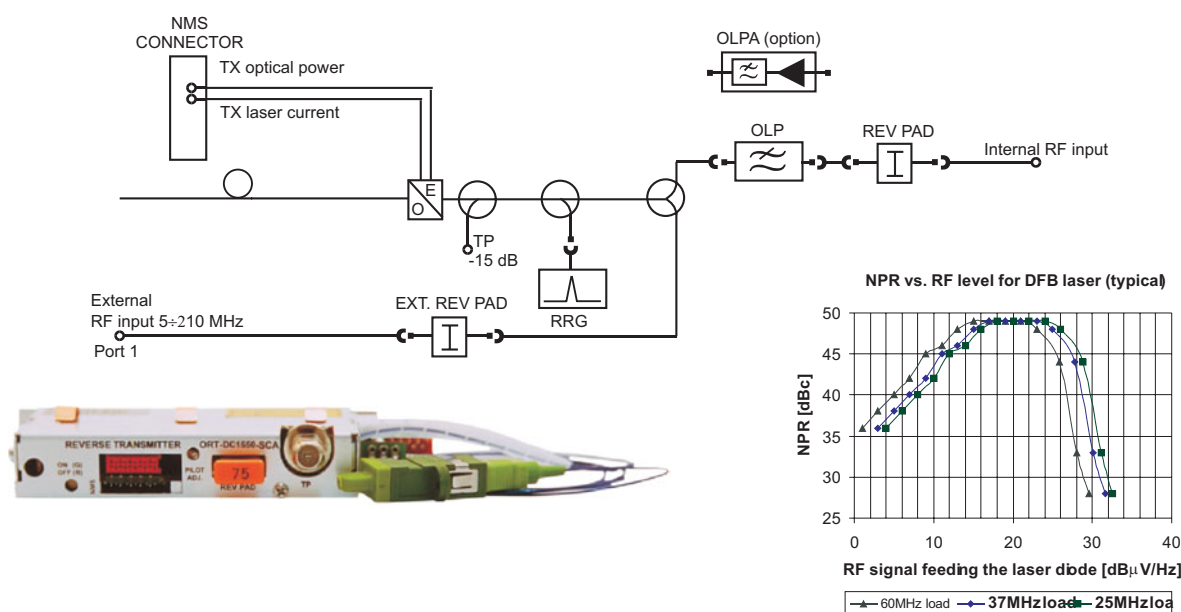

AGC 439-6

Automatic gain control module controlled by pilot tone

TECHNICAL PARAMETERS

Control Range [dB]	8
Pilot frequency [MHz]	439,25*
Output Level Stability [dB]	± 1
Insertion Loss [dB]	3
Operating Temperature Range [°C]	-40 ÷ +60

* Other AGC pilot control pilot control frequencies available, refer to ordering

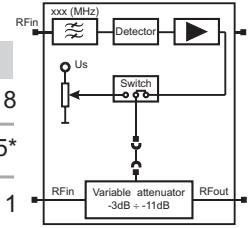

AGC 000-x

Automatic gain control module controlled by optical power at the input of receiver

TECHNICAL PARAMETERS

Bandwidth [MHz]	<ul style="list-style-type: none"> AGC 000-6: 85 ÷ 862 AGC 000-5: 75 ÷ 862 AGC 000-4: 54 ÷ 862 AGC 000-3: 47 ÷ 862 	AGC insertion loss [dB]	3,5
Control range [dB]	8	Stability over ± 2dBm input optical power change [dB]	± 1

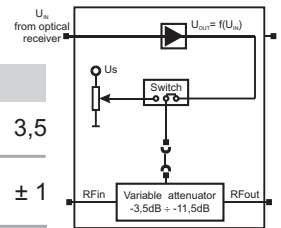

ASC 439-6

Automatic slope and gain control module controlled by pilot tone

TECHNICAL PARAMETERS

Control Range [dB]	3
Pilot frequency [MHz]	439,25*
Output Level Stability [dB]	± 1
Insertion Loss @ for 862MHz [dB]	4
Operating Temperature Range [°C]	-40 ÷ +60

* Other ASC pilot control frequencies available, refer to ordering

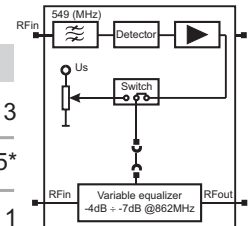

HPG xx

Forward path high-pass filter module

Bandwidth [MHz]:

- HPG 65: 85 ÷ 862
- HPG 42: 54 ÷ 862
- HPG 30: 47 ÷ 862
- HPG 30: 75 ÷ 862



RCA

Module for coaxial reverse output

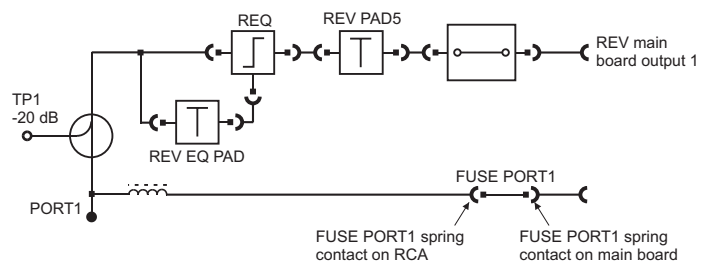

CKG 01

Optical Node Conversion Kit

Kit includes:

- optical input adapter PG-16
- fibre holders
- cover plate
- mounting screws

RAG 29-1, RAG 29-1/55/, RAG 29-1/42/, RAG 29-1/30/

Reverse amplifier module for single reverse path

TECHNICAL PARAMETERS

Maximum gain for configuration module RCG 04 [dB]	$29 \pm 0,75$	Intermodulation distortions:	
Bandwidth [MHz]		• third order beat IMD3 @ 110dB μ V ¹ [dBc]	≤ -60
• RAG 29-1	$5 \div 65$	• second order beat IMD2 @ 102dB μ V ¹ [dBc]	≤ -60
• RAG 29-1/55/	$5 \div 55$		
• RAG 29-1/42/	$5 \div 42$		
• RAG 29-1/30/	$5 \div 30$		
Flatness [dB]	$\pm 0,7$	Power consumption [W]	1,2
Noise figure for configuration module RCG 04 [dB]	≤ 6	¹ According to EN 50083-3	
NPR [dBc] for:			
• 60 MHz load @ 27dB μ V/Hz	≤ -60		
• 55 MHz load @ 28dB μ V/Hz	≤ -60		
• 37 MHz load @ 29dB μ V/Hz	≤ -60		
• 25 MHz load @ 30dB μ V/Hz	≤ -60		

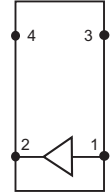

RAG 29-2, RAG 29-2/55/, RAG 29-2/42/, RAG 29-2/30/

Reverse amplifier module for dual reverse path

TECHNICAL PARAMETERS

Maximum gain for configuration module RCG 04 [dB]	$2 \times 29 \pm 0,75$	Intermodulation distortions:	
Bandwidth [MHz]		• third order beat IMD3 @ 110dB μ V ¹ [dBc]	≤ -60
• RAG 29-2	$5 \div 65$	• second order beat IMD2 @ 102dB μ V ¹ [dBc]	≤ -60
• RAG 29-2/55/	$5 \div 55$		
• RAG 29-2/42/	$5 \div 42$		
• RAG 29-2/30/	$5 \div 30$		
Flatness [dB]	$\pm 0,7$	Power consumption [W]	2,4
Noise figure for configuration	≤ 6	¹ According to EN 50083-3	
NPR [dBc] for:			
• 60 MHz load @ 27dB μ V/Hz	≤ -60		
• 50 MHz load @ 28dB μ V/Hz	≤ -60		
• 37 MHz load @ 29dB μ V/Hz	≤ -60		
• 25 MHz load @ 30dB μ V/Hz	≤ -60		

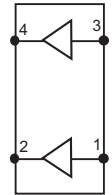

RCG 01

Reverse configuration module

Used for 3-outputs distribution amplifier or 3-outputs optical node with single reverse path. Provides equal sum of ports 2, 3 and 4.

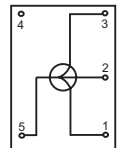

RCG 02

Reverse configuration module

Used for 3-outputs optical node with dual reverse path.

Provides equal sum of ports 2 and 3. Port 4 is configured as an independent reverse path.

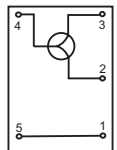

RCG 03

Reverse configuration module

Used for 2-outputs distribution amplifier or 2-outputs optical node with single reverse path as well as for 3-outputs optical node with dual reverse path.

Provides equal sum of ports 3 and 4. Port 2 is configured as an independent reverse path (for 3-outputs optical node).

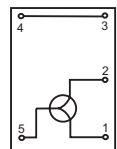

RCG 04

Reverse configuration module

Used for 1-outputs optical node with single reverse path or for 2-outputs optical node with dual reverse path. Ports 3 and 4 are configured as independent reverse paths (for 2-outputs optical node)

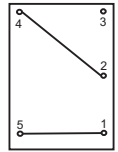

RCG 05

Reverse configuration module

Used for 3-outputs optical node with dual reverse path. Allows redundant transmission while using redundant optical transmitter.

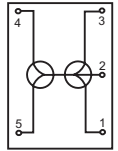

RCG 06

Reverse configuration module

Used for 2-outputs optical node with dual reverse path. Allows redundant transmission while using redundant optical transmitter.

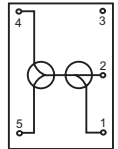

RCG 07

Reverse configuration module

Used for 1-output optical node with dual reverse path. Allows redundant transmission while using redundant optical transmitter.

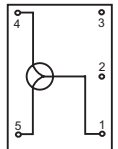

ISG 65

Ingress switch module

Used with Network Management System

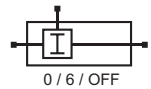

OLPA 65

Active band-pass filter module 5 ÷ 65 MHz for optical transmitter
Provides gain of 20dB.



OLPA 42

Active band-pass filter module 5 ÷ 42 MHz for optical transmitter
Provides gain of 20dB.



OLPA 30

Active band-pass filter module 5 ÷ 30 MHz for optical transmitter
Provides gain of 20dB.



DF 65A

Diplex filter module

Frequency range: 5 ÷ 65 / 85 ÷ 862 MHz



DF 55A

Diplex filter module

Frequency range: 5 ÷ 55 / 75 ÷ 862 MHz



DF 42A

Diplex filter module

Frequency range: 5 ÷ 42 / 54 ÷ 862 MHz



DF 30A

Diplex filter module

Frequency range: 5 ÷ 30 / 47 ÷ 862 MHz



EQ 801 ÷ EQ 824

Forward path fixed equalizer module

Equalization range 1 ÷ 24dB with step 1



EQSG 805 ÷ EQSG 811

Forward path fixed system equalizer module for optimizing the characteristic of cascaded GAMMA

Installed at the input or interstage equalizer socket allows to improve flatness of the frequency response to $\pm 1,5$ dB.

Equalization range $5 \div 11$ dB with step 1 dB.

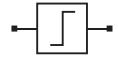

CS 80x

Forward path cable simulator module

x - signal attenuation @ 862MHz [dB] (x = 3; 6)



AT 800

Forward jumper module

Installed in place of diplex filters and/or forward equalizers if they are not used

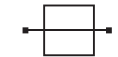

ATG 800 ÷ ATG 820

Fixed attenuator module

Used in forward and reverse path. Attenuation range $0 \div 20$ dB with step 1



REQ 65

Reverse path equalizer module

Equalization is determined by ATG 8xx attenuator (REV EQ PAD)

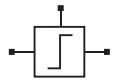

REQ 55

Reverse path equalizer module

Equalization is determined by ATG 8xx attenuator (REV EQ PAD)

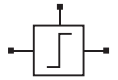

REQ 42

Reverse path equalizer module

Equalization is determined by ATG 8xx attenuator (REV EQ PAD)

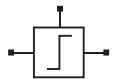

REQ 30

Reverse path equalizer module

Equalization is determined by ATG 8xx attenuator (REV EQ PAD)

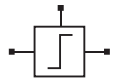

RJP

Reverse jumper module

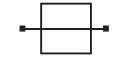

RHP 15

High pass filter 15MHz module for reverse path



ATG 075

Terminator 75 Ω module

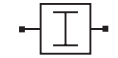

RRG xxx

Single tone reference generator module

xxx - frequency tone [MHz]

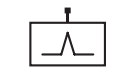

PSG 65

Switch mode power supply (SMPS) module

$35 \div 65$ V AC

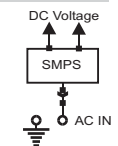

PSG 90

Switch mode power supply (SMPS) module

$40 \div 90$ V AC

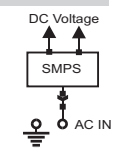

PSG 230

Switch mode power supply (SMPS) module

$187 \div 253$ V AC

