



BKtel
Systems

CABLEwatch

**HMS COMPATIBLE
NETWORK MANAGEMENT SYSTEM**

SYSTEM DESCRIPTION

TABLE OF CONTENTS

- 1 Principle of the HFC Network Management System 3
- 2 CABLEwatch Product Family 4
 - 2.1 Specified interfaces..... 5
- 3 CABLEwatch EMS 7
 - 3.1 Applications 7
 - 3.2 Functions 8
- 4 System data of CABLEwatch EMS 9
- 5 CABLEwatch MD 10
 - 5.1 Standard features 11
 - 5.2 Technical data of CABLEwatch MD 11
- 6 CABLEwatch HEC..... 12
 - 6.1 Standard features 12
 - 6.2 Technical data of CABLEwatch HEC 12
- 7 Network Element Controller 14
 - 7.1 Model of NEC in the Head end and Distribution Hub 14
 - 7.2 Function of the HMS-Concentrator XCON 15
 - 7.3 Function of the NEC in the MFN or MCxN 15
- 8 SNMP MIBs..... 17
- 9 CABLEwatch LMT 18

1 Principle of the HFC Network Management System

The developed monitoring system for both BKTel's HFC-862-MHz-system and any other HFC-network, is based upon the HMS-specifications (Hybrid Management Sub-Layer Subcommittee), currently designed and approved by the Society of CABLE Telecommunications Engineers (SCTE) as an open standard.

The system is providing a standardized SNMP-interface for an upper layer network management system.

As mediation device between the SNMP-manager and the HFC-network elements a head end Controller (HEC) is used.

The connection to the upper layer network management system and to element management system is provided through a standard SNMP-interface.

Connecting the network elements via the HFC-network the HEC provides a HMS interface over RF. The HEC can be installed and operated independently in head end locations or in HUB locations.

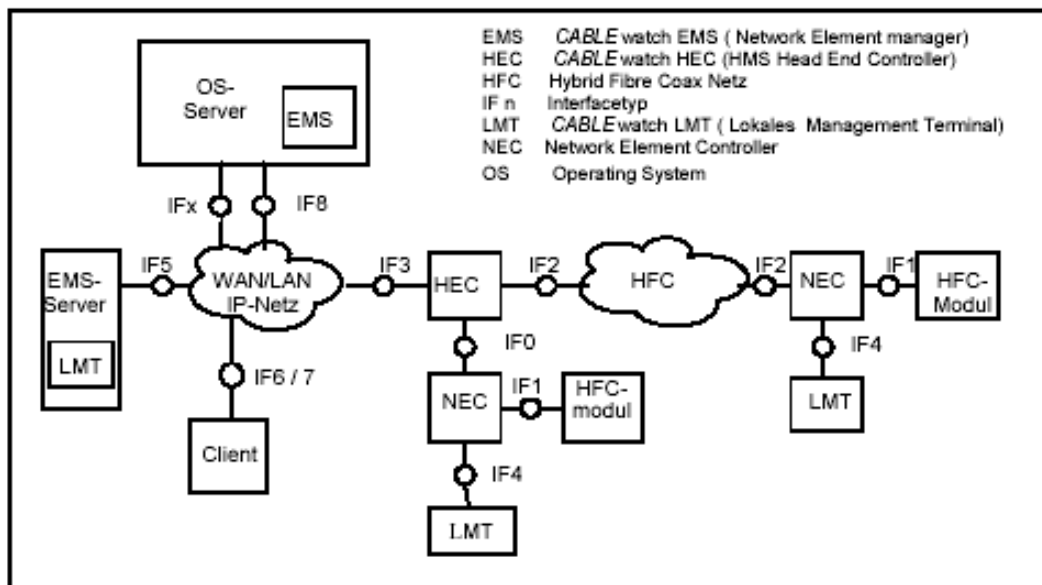

Figure 1: Reference model of HFC network with management interfaces

All building blocks and interfaces of the chosen HFC reference model are well defined.

Each network element controller (NEC) has its own management interface, which is connectable to the HEC.

To work directly with the network element, the craft personnel may connect a Local Management Terminal (LMT) to the network element controller (NEC). The LMT provides management functions to display status information and configuration parameter of a network element.

The LMT may also be used to setup a session to a network element in the HFC network via a direct connection to the management-LAN in the head end location, thanks to the HEC gateway function.

The LMT functionality is reused in the EMS. This means the same look and feel for the NE is handled in the LMT as well as in the EMS.

2 CABLEwatch Product Family

The above-defined principle is supported by the CABLEwatch product family to provide all necessary management functions and allows building a state of the art HFC network management system configurable to customer demands.

The product names are the following:

- CABLEwatch EMS (Element management system)
- CABLEwatch LMT (Local Management Terminal)
- CABLEwatch MD (Mediation device)
- CABLEwatch HEC (Head end controller)

According to the reference model shown above, the management products CABLEwatch LMT and CABLEwatch EMS use the same software component or subsystem for displaying the network element with physical and functional views.

This is a basic guideline for the operation of a HFC network with Bktel CABLEwatch management products, helping the operators (in the management center and remote on site) discussing the same screen data.

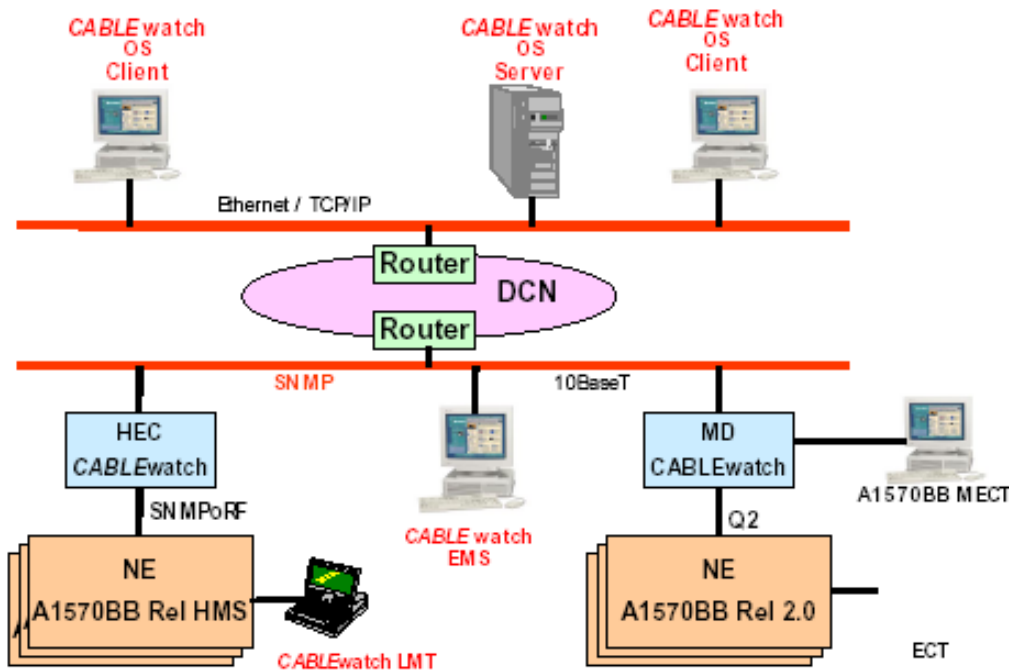

Figure 2: CABLEwatch product family

A short introduction will make you familiar with each product:

CABLEwatch EMS

CABLEwatch EMS (Element management system) is a multi client system to operate any HFC network with up to 500 network elements connected to a CABLEwatch HEC or CABLEwatch MD.

CABLEwatch LMT

The CABLEwatch LMT (Local Management Terminal) consists of an SNMP manager managing one network element.

Installation or maintenance personnel, connecting it to a NE for installation and maintenance purposes, use this device.

The hardware is a standard PC or Laptop with WIN95/98/NT software.

CABLEwatch

HMS Network Management System



CABLEwatch MD

CABLEwatch MD is a mediation device providing functions to convert the BKTel Q2 protocol information of existing 1570BB network elements into SNMP information for CABLEwatch EMS.

It is a one-unit high 19inch device, installed typically in the head end location.

CABLEwatch HEC

CABLEwatch HEC is a HMS compliant head end controller, which is needed to communicate downstream and upstream with 1570BB HMS compliant network element controller with transponder via RF signal. The CABLEwatch HEC transports the SNMP information from the NEs to the CABLEwatch EMS.

2.1 Specified interfaces

A short introduction of the communication of the CABLEwatch products via the specified interfaces. Regarding the chosen reference model, shown in figure 1, the interfaces are listed and described as an overview:

- **IF 0:**
Is the interface of the HEC to the NEC. It represents the layer 1 to 3 using RS 485, HMS004 and SNMP over RF. It allows local connection to NE s, mounted in the same station as the HEC.
- **IF 1:**
Is the interface between the NEC and the HFC modules, representing an NE
- **IF 2:**
Is the interface between HEC / NEC and the HFC network. It represents the layers 1 to 3 of HMS standard with HMS005, HMS004 and SNMP.
- **IF 3:**
Is the interface between the IP network and the HEC. It represents the layers 1 to 4 of industry standard Ethernet, IP, ICMP, UDP and SNMP.
- **IF 4:**
Is the interface between the NEC and the LMT. It represents the layers using RS232, HMS22 and SNMP.
- **IF 5:**
Is the interface between the IP network and the EMS server. It represents the layers 1 to 4 of industry standard Ethernet, IP, ICMP, UDP and SNMP.
- **IF 6:**
Is the interface between the IP network and the client. It represents the layers 1 to 4 of industry standard Ethernet, TCP/ IP.
- **IF 7:**
Is the interface between the IP network and the client. It represents the layers 1 to 4 of industry standard Ethernet, TCP/IP and HTTP.
- **IF 8:**
Is the interface between the IP network and the OS server. It represents the layers 1 to 5 of industry standard Ethernet, IP, ICMP, TCP, SNMP and HTTP.
- **IF x:**
Is the interface between the IP network and the OS server. It represents the layer 1 to 5 of industry standard Ethernet, IP, ICMP, TCP, SNMP or other specific protocols used by integrated EMS.

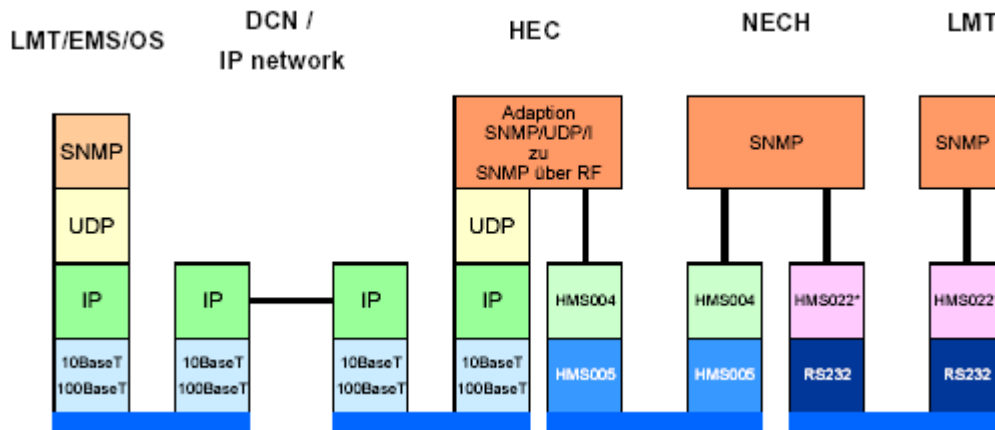

Figure 3: Used protocol stacks for the defined interfaces

This figure shows part of the communication via the defined interfaces

The product portfolio of the *CABLEwatch* family provides a cost effective, modern and scalable solution for HFC operators.

The HFC network-layout may look like the figure shown below, representing a HFC core network for analogue and digital video distribution additionally with overlay networks for *CABLE* modems for data communication and circuit based telephony or VoIP communication.

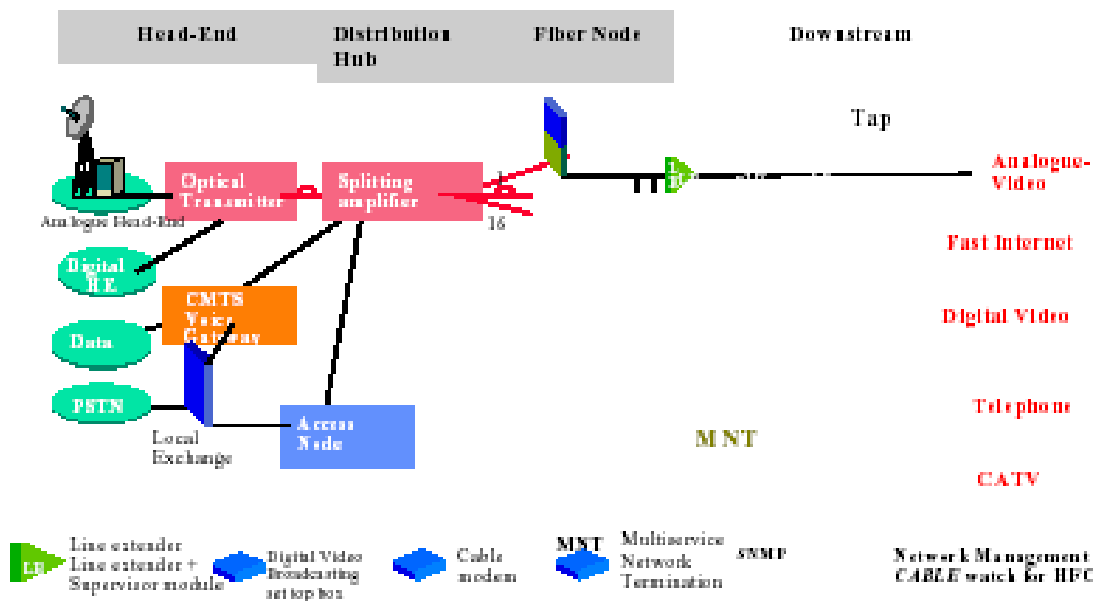

Figure 4: model for a HFC multi-service network

In Figure 4 the *CABLEwatch* product family is shown with the connection to the 1570BB HFC core network elements.

3 CABLEwatch EMS

CABLEwatch EMS (Element Management System) complies with the requirements of the above shown reference model and interfaces via IF 5 and IF 6.

CABLEwatch EMS is delivered as a Multi-User system based on a Client/Server software for up to 5 users, executable on a standard PC environment. If wanted, CABLEwatch EMS can be configured as a Single-User system running on only one PC.

The server device with the dedicated software runs on an industry PC environment and is typically installed in a head end equipment rack. The client PCs are connected via a LAN (Ethernet) with the server. In both product variants a SNMP-manager is the basis for the operation of the connected HMS network elements.

CABLEwatch EMS is based on WINNT4.0 (2000/XP).

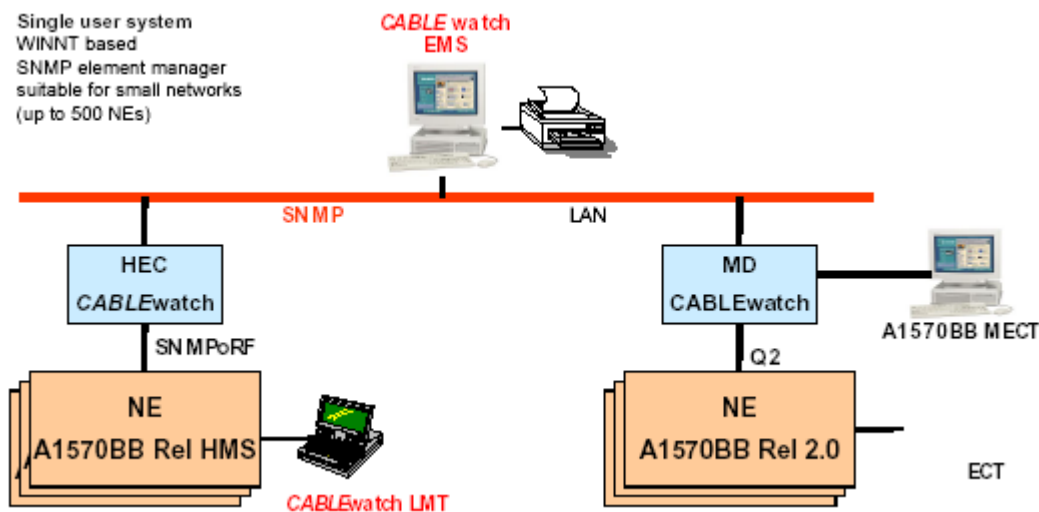

Figure 5: CABLEwatch EMS overview single user system

3.1 Applications

The data structure of all applications is based on SNMP-MIBs. The dialog between the EMS and the NE is via SNMP.

Every managed NE must have an individual IP address. It must be configured at the CABLEwatch EMS during the installation process.

The following applications are available:

Login

The user types in a password and a User-ID to login.

The Logout function disconnects the relevant user from the application software of CABLEwatch EMS.

System configuration

During the installation of the system, the relevant parameters for users, logs, time and date, communication ports, HMS-NEs and the reachable IP addresses have to be made known to the CABLEwatch EMS.

The explorer shows all configured NEs and applications connected to the database.

Network views

The NEs are displayed with graphical objects.

The operator may generate network views according to the real network size with links connecting the objects.

A location name is attachable to each object.

Network elements are also represented through physical views.

Alarms received will change the colors of the objects in the views, according to the severity.

3.2 Functions

Alarms are received from the NEs via SNMP-traps and are processed in *CABLEwatch* EMS. The information is stored in the Alarm-Log with detailed information about date and time, source, type, severity, possible cause, state of acknowledgement.

The operator may select via a filter function the details he is just interested in for his work to do.

As an overview further functions are provided:

- Alarm severity is shown in colour of the text information. This is a hint to the operator to select the most critical alarms and work on them as a priority.
- The configuration of network elements is possible via proposed menus.
- The measurement data from network elements are displayed on operator request.
- Inventory-date will be processed out of the NE-MIB. The operator may read the dedicated board information or the processed information of a whole NE.
- Via software-download the NE -Software (Firmware) can be loaded into the NE-controller. The procedure is guided by an application in the *CABLEwatch* EMS.
- Online-help supports the operator via context sensitive connection from every menu and view to the electronically stored user manual.
- All managed network elements as well as the correlated MIBs will be made known to *CABLEwatch* EMS during installation phase of a project. Changes can be processed through an available MIB compiler.
- A connected printer may be used to printout the content of views and logs.

4 System data of CABLEwatch EMS

EMS Server

The EMS Server consists of a PC standard rack. The PC is equipped with a Processor and suitable memory. Optional Raid-technology (RAID 1) allows the change of hard disks during operation (hot swap) without losing any data.

Communication interfaces are basically RS232-ports, RS485-ports and 10Base-T Ethernet-interface.

A SNMP-manager is implemented, to get and send data via the CABLEwatch HEC to/from the HMS-network elements.

A SNMP-agent is implemented, to send information CABLEwatch EMS to an upper layer management-system.

The design of the software is modular and additional functions may be added in future.

Definition:

- IBM compatible PC
- Pentium III Processor
- 512 MB RAM
- Ethernet LAN
- Windows NT 4.0
- Software design modular
- Client/Server architecture

Specification

- Temperature range: 10-35 °C
- Power: 300W 80-132 VAC/180-260VAC
- Power consumption: 120W max. 90W typically

EMS Client

CABLEwatch EMS Client consists of a standard PC with the following data

- Pentium III
- 350MHz
- 256 MB RAM
- >8GB HD
- 17inch colour screen
- Resolution min. 1024x768
- CD-ROM drive
- 3,5 FD drive
- Network Interface Card 10BaseT/100BaseT
- Windows NT 4.0
- CABLE set

5 CABLEwatch MD

CABLEwatch MD is a mediation device with gateway functionality for connecting to BKTel Q2 compliant network elements of an OS.

The connection between OS and the MD is provided by a standard SNMP / IP / Ethernet protocol. CABLEwatch MD provides an SNMP agent with multi homing IP addressing capability.

CABLEwatch MD provides as well a BKTel Q2 manager to make the connection to each NE using BKTel Q2 protocol via a dedicated management link to each distribution hub. A mapping function exchanges the data from the Q2 manager to the SNMP agent and the MIB and vice versa.

The CABLEwatch MD is mounted in the rack together with the head end equipment of 1570BB.

Direct connection to NEs via BKTel Q2 over an RS485 Bus is used for head end NEs. For the concentration of management information and the connection link to the distribution hubs 1570BB equipment is used

Also a separate communication network may be used, if no upstream fiber between head end and hubs are available. In this case in every distribution hub a CABLEwatch MD has to be installed.

The functions of the CABLEwatch MD at the SNMP interface are compliant to the specifications designed and approved by SCTE Hybrid Management Sub-Layer Subcommittee.

CABLEwatch MD can communicate thanks to its standard SNMP interface with CABLEwatch EMS and with every standard SNMP manager on the market.

The capacity of a CABLEwatch MD is 254 network elements via up to 4 Q2 interfaces.

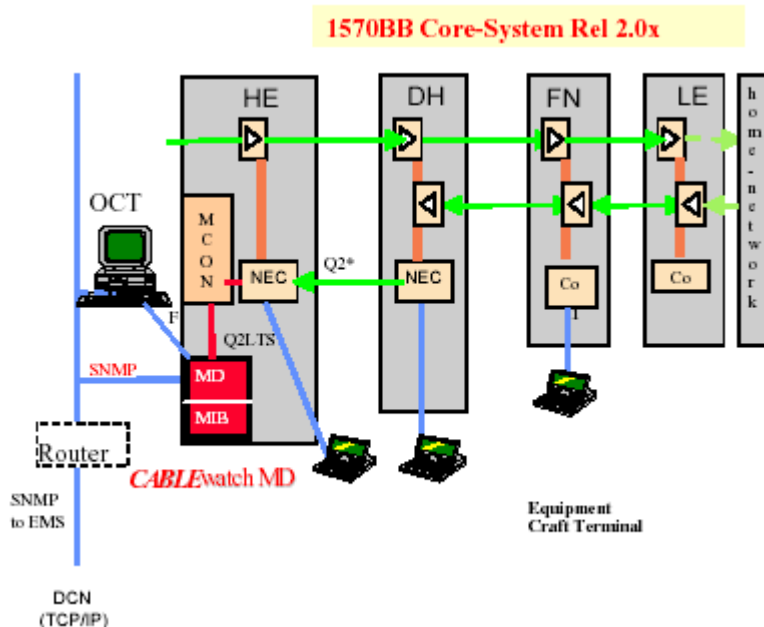

Figure 6: 1570BB Rel. 2.0J with CABLEwatch MD

Figure 6 shows the communication principle for the 1570BB network element release 2.0J is explained. The CABLEwatch MD is mounted in the head-end location in a 19 inch rack.

CABLEwatch

HMS Network Management System

5.1 Standard features

- Compact solution
- Reliable, maintenance-free (no fans; no hard-disk)
- 4 x Q2 interfaces
- Operates in polling mode to Q2 NEs
- High throughput and response times
- Auto discovery of NEs by SNMP agent
- Converts SNMP access to each NE
- SNMP MIB for each Q2 NE (HMS compliant structure)
- SNMP MIB for *CABLEwatch* MD itself (HMS compliant structure)
- Environment management capability via Remote Control (RC) and Remote Signaling (RS)
- 1570BB Rel. 2.0/J/L NEs supported
- Connection of OCT (office craft terminal) to manage NEs in detail



Figure 7: View on *CABLEwatch* MD device

5.2 Technical data of *CABLEwatch* MD

General specifications:

Power supply	36 - 60 VDC (\pm 20%)
Power consumption	10 W
Weight	ca. 3 kg
Dimensions	in mm 44.5 height x 450 width x 180 depth
Climatic conditions	ETS 300 019 1, 2, 3
Max. temperature	+40°C
Electromagnetic compatibility	ETS 300 386-1 EN 55022, Class B EN 50082-1
Product safety	EN 60950

The unit is designed to comply with the HMS MIB standards.

Embedded software updates can be done through TFTP or serial to adapt the unit to future versions of the HMS specifications and BKtel software.

Interface to management system:

Ethernet-Port 10/100BaseT protocols supported TCP/IP/SNMP

Q2 RS-485-port:

Via these ports the connection to the head end equipment and the communication concentrator is established.

RS-232-port:

Craft-terminal-interface Asynchronous point-to-point 9600 or 19200 bit/s

Management of environment:

Control outputs	3 RC
Signaling inputs	12 RS
Rack signaling	3 outputs (urgent, non urgent, attended)

Software features:

- MIB2 for the *CABLEwatch* MD itself
- Easy replacement of *CABLEwatch* MD.
The entire device configuration can be saved and transferred to spare device.
- Operating system pSOS

6 CABLEwatch HEC

CABLEwatch HEC is a head end controller with gateway function for connecting HMS compliant network elements from an OS. The connection between OS and the HEC is provided by a standard SNMP / IP / Ethernet protocol. Every network element is providing a HMS compliant communication and has its own SNMP agent with a dedicated IP address. CABLEwatch HEC is in charge to make the connection to each NE using HMS protocol via RF functions.

Direct connection to NEs via HMS over an RS485 Bus (Draft HMS070) is also possible. This is very comfortable for NEs installed in the same location as the CABLEwatch HEC.

The functions of the CABLEwatch HEC are compliant to the specifications designed and approved by SCTE Hybrid Management Sub-Layer Subcommittee.

CABLEwatch HEC can communicate thanks to its standard SNMP interface with CABLEwatch EMS, CABLEwatch OS and with every standard SNMP manager on the market.

It controls HMS compliant transponder for RF communication and so it is a general use device for monitoring purposes via RF.

Virtual IP address for each NE

A transparent SNMP-agent allows the connection to each transponder or NE using a virtual IP-address provided by the HMS manager in the HEC. Network elements can easily be implemented in network management systems. No complex procedures have to be developed getting access via proxy devices and multi homing IP address routing devices.

6.1 Standard features

- Compact solution
- Reliable, maintenance-free (no fans; no hard-disk)
- 8 separate receivers for exceptional noise resistance
- Can operate in polling as well as contention mode
- High throughput and response times; no collisions
- Wide frequency range in both downstream and upstream path
- Auto discovery of HMS compliant network elements
- Transparent SNMP access to each NE
- SNMP MIB for configuring of HEC settings
- Real-time measurement of upstream path levels
- Scalable: if more than 8 receivers are needed, additional HECs may be added without any implication on the software management model

6.2 Technical data of CABLEwatch HEC

General specifications:

Ambient temperature range:

within specs 10 - 40 °C / 50 – 104 °F

Operation 0 - 40 °C / 32 – 104 °F

Storage -20 - 80 °C / -4 – 176 °F

Power supply: 90 - 240 VAC ± 10% 47-63 Hz
or 36 - 60 VDC (± 20%)

Power consumption: 25 W

Weight: ca. 5 kg

Dimensions:

in Inch 1.75 H (1 HE) x 19 B x 18.5 T

in mm 44.5 H x 483 B x 470 T

The unit is designed to comply with the Physical Layer Specs SCTE HMS 005R6.

The embedded software complies with the SCTE HMS 004R7 MAC Layer Spec. Embedded software updates can be done through FTP to adapt the unit to future versions of the HMS specifications.

CABLEwatch

HMS Network Management System

HF-Transmitter

F-Connector	75 ohm - AC coupled
Frequency range	48 - 162 MHz in 50-kHz increments
FSK-modulator	HMS005 compliant ± 67 kHz
Output level	+36 ... +51 dBmV
Spurious	< -65 dBc

HF-Receivers

F-Connector	75 ohm - AC coupled
Frequency range	5 - 65 MHz in 50-kHz increments
FSK-modulator	HMS005 compliant ± 67 kHz
Input range	-20 ... +20 dBmV
BER	10-6 at 20 dB CNR (in 400 kHz bandwidth)

Interface to management system

Ethernet-Port 10/100BaseT

Measurement of incoming RF levels

On the fly measurements on incoming packet level are possible. Measured levels for each transponder are accessible in the SNMP MIB.

RS-485-port

This port is intended for managing head end fibre equipment through SCTE-HMS-MAC-protocol or other future serial protocols.

RS-232-port

Craft-terminal-interface / reserved for future extensions

Software features

- MIB2 for the gateway device itself
HEC MIB: SNMP-management for the gateway device itself (MIB for specification of transmit and receive frequencies, transmit level, receive level, auto discovery of transponders...). Easy replacement of CABLEwatch HEC. The entire device configuration can be saved and transferred to spare device.
- CABLEwatch LMT support
CABLEwatch LMT may connect to the HEC via LAN and allows setting the most useful configuration parameters.

7 Network Element Controller

The Network Element Controller (NEC) modules in the 1570BB HFC core system are the intelligent modules, which provide interfaces to

- Manage the boards for the transmission equipment
- CABLEwatch HEC
- CABLEwatch LMT

These NEC consist of hardware, software and the MIBs, detailed in categories for HMS-MIBs, CABLEwatch-MIBs, NE and board-MIBs.

There are NECs in the fibre nodes, coax nodes and different NECs in the head end and in the distribution hubs, due to the network configuration demand.

In the following figure the difference of the two types of NECs is visible related to the used interfaces.

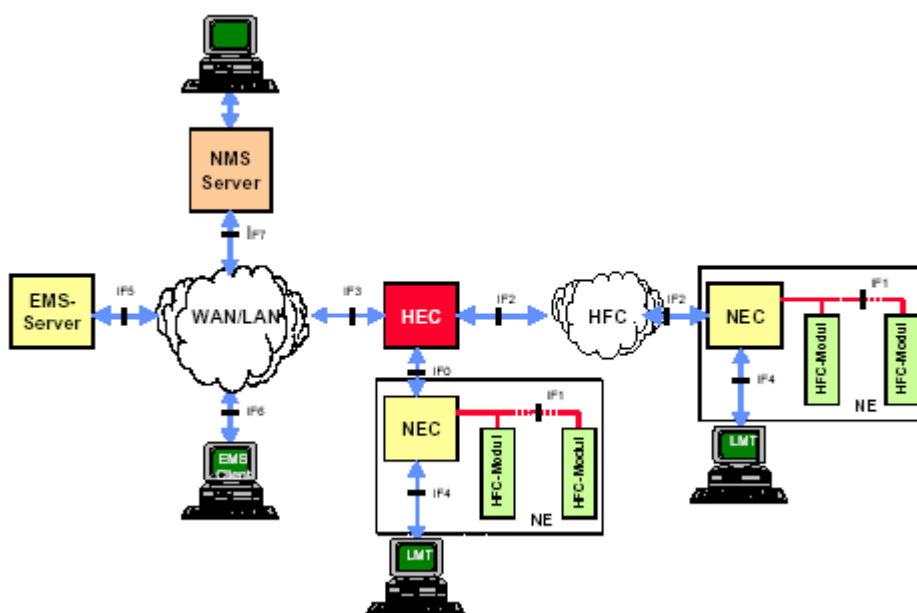

Figure 8: Overview of the two possible NE connections via the CABLEwatch HEC

7.1 Model of NEC in the Head end and Distribution Hub

The management functions are hosted in the NEC realized by type NECH and NECUH. Type NECH is a NEC with HMS protocol, realized in BK equipment practice. NECUH is a NEC for Upstream-modules with HMS protocol. The upstream equipment and as well the NECUH is realized in S9-equipment practice.

The functional overview of NECH and NECUH is shown in figure 3. CABLEwatch HEC and the NEC are communicating via IF0 compliant to HMS-standard. IF0 is used for direct connection via RS485-Bus, means HMS over RS485.

The NEC and the various transmission boards in BK equipment practice are connected via a powerful serial bus, based on LON technology of ECHELON.

The connection to CABLEwatch LMT is provided via the RS-232 interface IF4.

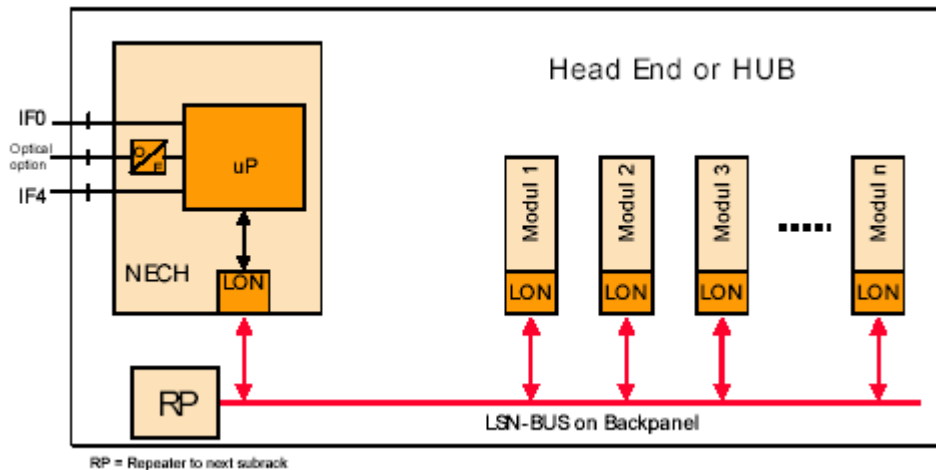

Figure 9: Functional overview for the NEC in the head end and hub equipment

7.2 Function of the HMS-Concentrator XCON

The task of the HMS-Concentrator XCON is to concentrate the "HMS over RS485" signals and send them to the RF-modem of a transponder. The XCON is therefore an interfacing device between "HMS over RF" and "HMS over RS 485". Regarding the management reference model the XCON converts the interface IF2 to IF0 and vice versa.

XCON is processing the IF2 downstream signal alternatively optical or electrical.

Inside the distribution hub using the XCON, if more than one NEC is installed only the XCON will have to be equipped with a transponder and all other NEC are communicating via the RS485 bus.

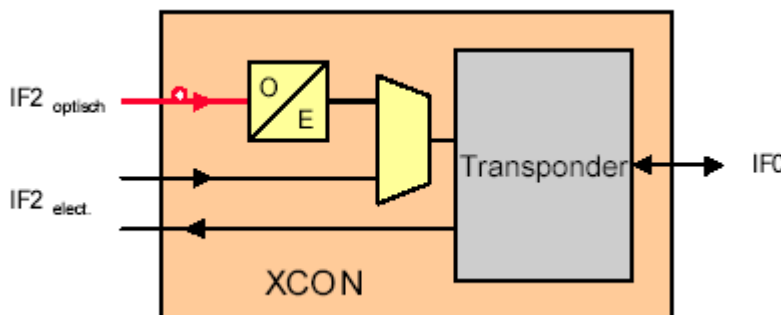

Figure 10: Functional overview of the HMS-concentrator XCON

7.3 Function of the NEC in the MFN or MCxN

The overview of the functions of a NEC for modular fibre node (MFN) or modular coax node (MCxN) is shown in the figure below.

CABLEwatch HEC and the NEC are communicating via IF2 compliant to HMS-standard. The NEC and the various transmission boards in BK equipment practice are connected via a powerful serial bus, the IF1 - based on LON technology of ECHELON.

The connection to CABLEwatch LMT is provided via interface IF4.

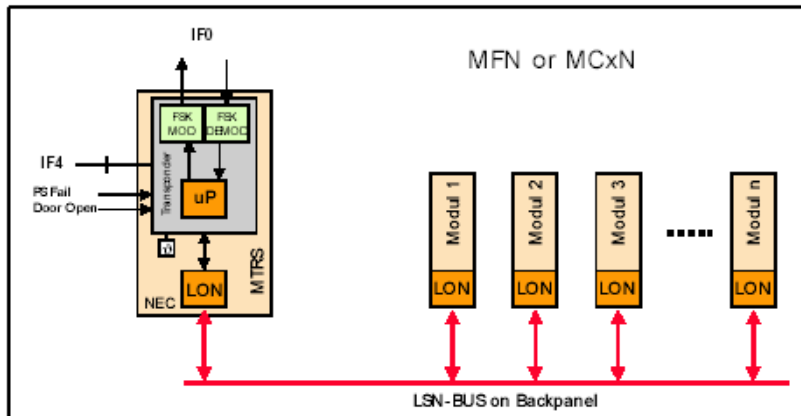

Figure 7-11: Overview of the NEC function in the MFN and MCxN

- NEC includes HMS compliant transponder with the following features:
 - Frequency agile HF-modem
 - Download firmware
 - Configurable alarm thresholds
 - Read measurement values in real time
 - Remote control of parameters
 - Storage of parameter in flash memory
 - Programmable address during manufacturing
 - Automatic return path leveling
 - Plug and play function

Via the analogue-interface the measured values as temperature, 24 VDC, receive- and transmit level are read. The connection to the LON-controller is made through the digital interface, which reads also the status of the power supply and the door-contact. The controller and the various transmission boards in BK equipment practice are connected via a powerful serial bus, the IF1 - based on LON technology of ECHELON.

Within the Echelon-system, each BK-module has its own unique address and is directly accessible.

The NEC uses one sub-rack position. *CABLEwatch* LMT is accessible via the front connector on the NEC board.

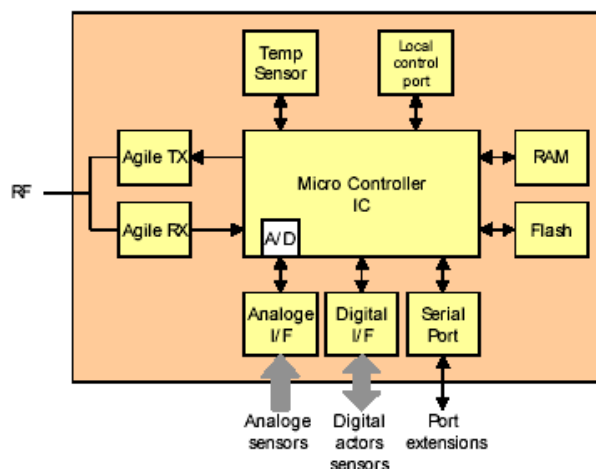

Figure 12: Overview of the transponder

8 SNMP MIBs

The NEC is hosting various MIB types related to the actual functions it has to manage. Those MIBs are the:

- HMS compliant MIBs
- CABLEwatch MIBs
- NE and board MIBs

The MIBs are provided with each dedicated NEC software package (firmware).

They are used together with CABLEwatch EMS and CABLEwatch LMT.

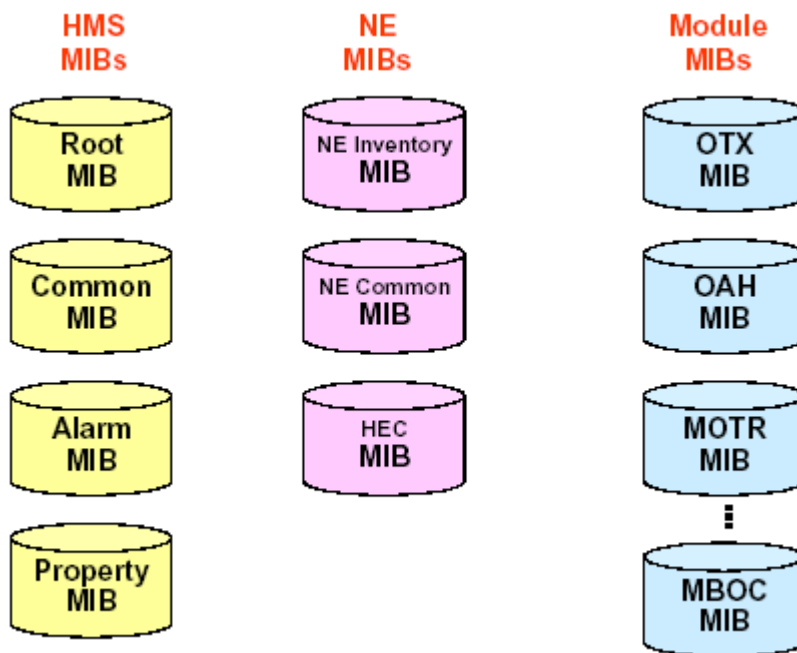

Figure 13: Overview of the used MIBs

9 CABLEwatch LMT

CABLEwatch LMT provides all functionality to operate a HMS based network element locally. In the following text it is short named as LMT.

The service operator connects the laptop to the RS232 port of the network element controller using a standard serial CABLE. The laptop must have the LMT software installed. The communication to the NE is thus established and the operator may activate directly the available functions using the user-friendly menu structure.

Operating and understanding the LMT, no detailed computer knowledge or even programming knowledge is required.

The GUI of the LMT is using the well known WINDOWS look & feel.

The LMT may be connected to all HMS compliant 1570BB network elements. Additionally via the LAN in the head end (connected to a standard CABLE (RJ45)), the LMT may access the network elements via CABLEwatch HEC.

The LMT software is integrated as the EML into the CABLEwatch EMS, providing the same views on the network elements hardware. This allows an effective dialogue between CABLEwatch EMS operator and maintenance personnel using the LMT in case of trouble shooting or repair actions on site.

Hardware

CABLEwatch LMT runs on a standard PC together with (system) OEM-software, application-software and the NE MIBs. Regarding the hardware, a Laptop PC is suggested, providing the following minimal configuration:

- Pentium III, 350MHz
- 256MB RAM, 10GB HD
- 14inch color screen resolution min. 1024 x 768
- CD-ROM drive
- 3,5 FD drive
- Network Interface Card 10BaseT/100BaseT
- WIN 95/98/NT
- CABLE set

Software

Next to the system OEM software WIN 95/98/NT, the LMT applications software and the NE MIBs are necessary to run any application.

Communication software allows exchanging data with the network element controller (NEC) via a RS 232 interface.

The LMT application-software is designed modular and includes 7 main parts:

- Application functions
- MIB-Browser
- View-Editor
- View-Runtime function
- System configuration function
- SNMP-Manager
- Communications function.

The NE-MIBs are loadable into the LMT performing the basic application functions. The software for the NEC can be downloaded via the communication function of the LMT.

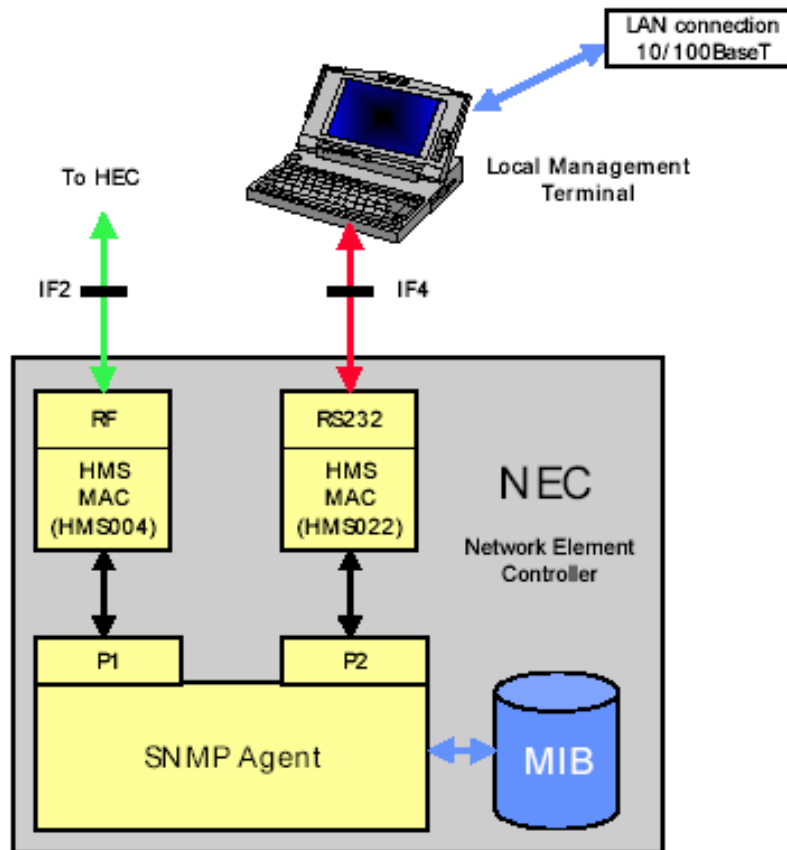

Figure 14: Principle connection to the network element controller via external interfaces

Application

After starting the LMT application from the WINDOWS shell and passing the login procedure, the application is running.

The applications are using the data of the connected NE MIBs. There are no other data needed. Of course the IP-address of the connected NE must be known and keyed in on request by the LMT. In case of directly serial connection to a NE, the IP address is not needed.

Network element views of an NE are depending of the function and size and may consist of:

- A rack
- A subrack
- And boards

Physical views and logical views are possible to be displayed.

Provided by available menus, the next items will be shown in collared graphical objects:

- Status of the NE
- Status of boards
- Status of communication

The main functions of the applications are listed below:

- Configuration is possible via the provided menus.
- The measured values will be displayed after request.
- The inventory data may be read from an individual board or all boards in the NE. This information is displayed and may be saved or printed to a connected printer.
- The status of synchronization of the NE with the CABLEwatch HEC is also read from the NE-MIB and displayed.
- When the LMT is connected, all traps of the NEC are stored in the event log. The content of the log may be printed to a connected printer.
- A help manual is provided in PDF format.
- Administrative functions allowing to:
 - reset the NE
 - change the IP-address of the NEC
 - download the NEC Software
 - reset, reorder or filter the event log
 - change graphical views
 - automatically reconnect when the LMT was disconnected from the NEC
 - logout the operator

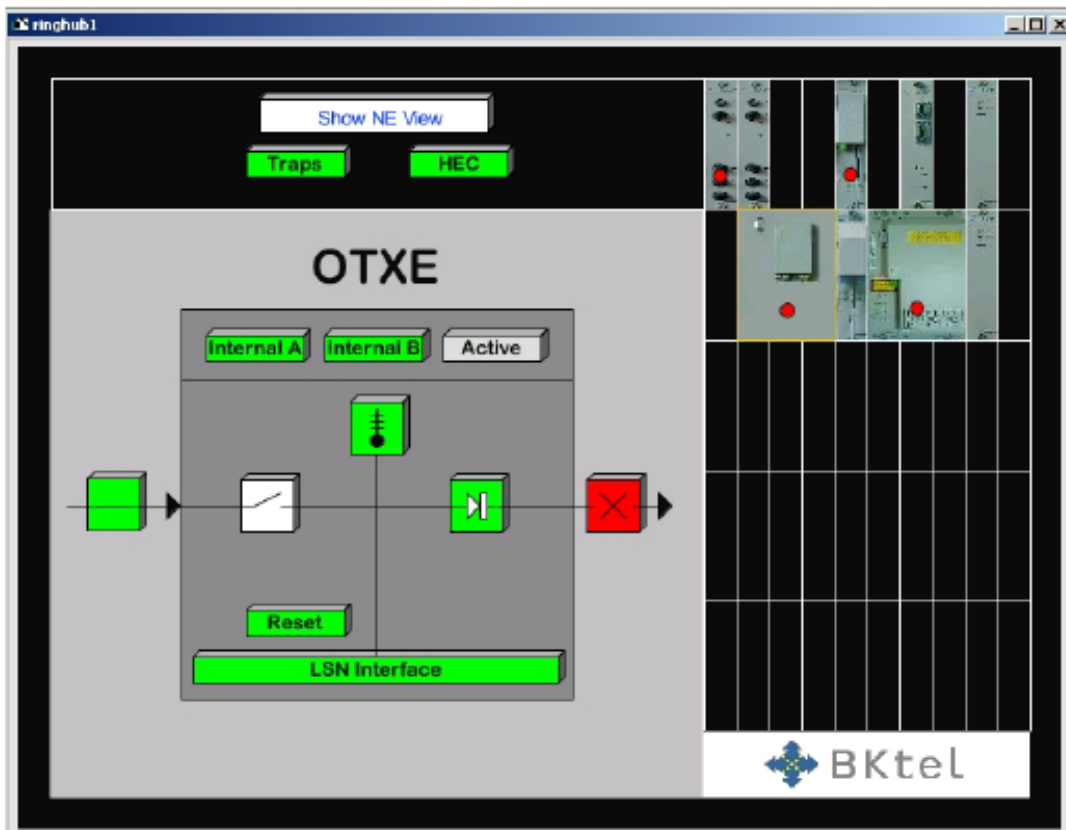

Figure 15: Example of a board level view of the NE: optical transmitter