

BOT 265

Optical return path transmitter CWDM

General:

The BOT265 is a dual optical transmitter for upstream CWDM applications in modern HFC networks. The two transmitter parts are specially designed to meet today's requirements for easy, cost-effective network segmentation using CWDM techniques for optimal fiber employment. The integration of 2 transmitters in a single BK-housing is the space-reducing solution for efficient segmentation of the upstream-path in an optical BK-node.



Features:

- DFB-Laser, CWDM, optical output level 3dBm or 6dBm;
- Optical connector type E2000 (others on request);
- Frequency range 5 - 65 MHz;
- Min. input level 65dBμV for OMI = 15% (fixed gain);
- RIN= - 141dB/Hz;
- Pluggable attenuator JXP 0...20dB (interstage);
- Input connector IEC-female
- Tap -20 dB on input (IEC-female);
- Testpoint -20dB on amplifier output, internal F-female;
- BK type housing.

Block diagram:

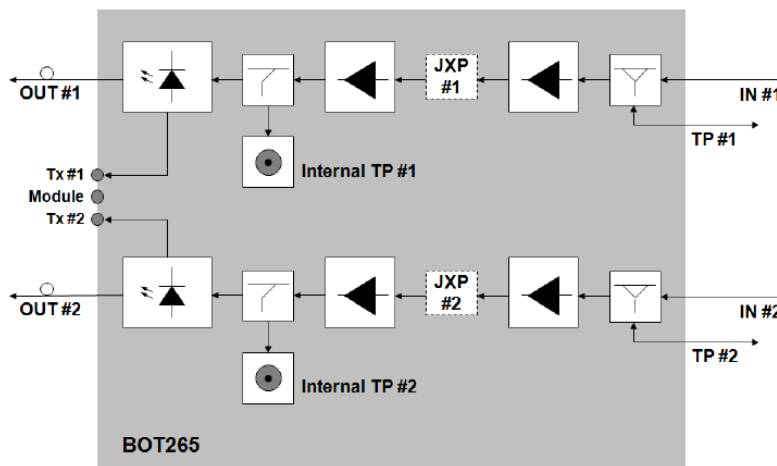

Optical Properties

Wavelength		
BOT265-1310-03/1310-03	[nm]	1310 and 1310
BOT265-C11-03/C12-03	[nm]	1471 and 1491
BOT265-C13-03/C14-03	[nm]	1511 and 1531
BOT265-C15-03/C16-03	[nm]	1551 and 1571
BOT265-C17-03/C18-03	[nm]	1591 and 1611
Wavelength		
BOT265-1310-06/1310-06	[nm]	1310 and 1310
BOT265-C11-06/C12-06	[nm]	1471 and 1491
BOT265-C13-06/C14-06	[nm]	1511 and 1531
BOT265-C15-06/C16-06	[nm]	1551 and 1571
BOT265-C17-06/C18-06	[nm]	1591 and 1611

Wavelength Tolerance (for full temperature range)	[nm]	± 6
Optical power	[dBm]	3 or 6
Laser Type		un-cooled DFB laser with optical isolator
Optical power tolerance	[dB]	± 1.0
Optical return loss	[dB]	> 35
Relative Intensity Noise RIN (JXP= 0dB)	[dBc/Hz]	< -141

Electrical Properties

RF-Frequency Range	[MHz]	5 – 65
Flatness	[dB]	<±0.5 @ 5 ... 65 MHz
IM2 (2 carriers with OMI = 20% each, JXP= 0dB)	[dBc]	> 44
IM3 (2 carriers with OMI = 20% each, JXP= 0dB)	[dBc]	> 50

Generic Data

Optical Connector		Any type of high return loss connector
Min. Input Level per QAM Channel (for OMI = 15%)	[dBμV]	65 ±1
Ref. Input Level of Insertion Input/Test-Point ref. to Main Input (bidirectional)	[dB]	20 ±2
Laser Driver Test-point output level (referring to OMI = 15%)	[dBμV]	Typical 80 ±2
RF attenuator adjustment range (JXP)	[dB]	0... 24
RF return loss (all RF ports, referring to 75 Ohms)	[dB]	>18 (5 ... 65 MHz)
Climatic Specification Operation*) Transportation Transportation Storage		ETS 300 019-1-3, class 3.1 ETS 300 019-1-2, class 2.2 (mechanical conditions only) ETS 300 019-1-2, class 2.3 (all other conditions) ETS 300 019-1-1, class 1.1
Laser Safety according to IEC60825		Hazard Level 1M "eye-safe for normal viewing"
Product safety		EN50083-1 EN60950
EMC		EN50083-2
Power Supply Voltage	[VDC]	24
Power Consumption	[W]	< 3
Enclosure		BK-type housing, 1 slot unit
Weight	[kg]	1.3

*) Operation temperature range is related to a module backplane temperature between 0°C and 60°C. This corresponds to the condition that the module is mounted on a BK sub-rack (BBT00x) with restricted total power dissipation of 90 W, no enforced cooling and with the sub-rack being operated in a temperature controlled location according to ETS 300 019-1-3, class 3.1.