

BOT 2900

Dual Optical Forward Transmitter

General:

The BOT2900 is a dual optical transmitter for downstream applications in modern HFC networks. The two transmitter parts are specially designed to meet today's requirements for easy, cost-effective network segmentation using CWDM techniques for optimal fiber employment. The integration of 2 transmitters in a single BK-housing is the space-reducing solution for efficient clustering of the downstream-path in an optical BK-Hub.

The BOT2900 can be equipped with both standard and CWDM type lasers.

Features:

- Dual optical forward transmitter with two individual RF inputs and two testpoints
- 1310nm and CWDM (C01: 1271nm ... C06: 1371nm)
- DFB laser with pre-distortion technology
- +6 dBm standard 1310 nm and CWDM O-band optical output power
- High decoupling of RF inputs
- All-electronically adjustments of gain and OMI
- Automatic load control (ALC) for constant OMItrrms
- RS485 control interface
- SC/APC or E2000 connector as standard
- Very compact, modular BK-type housing
- Tap -20 dB on input (IEC-female);
- BK type housing.



Block diagram:

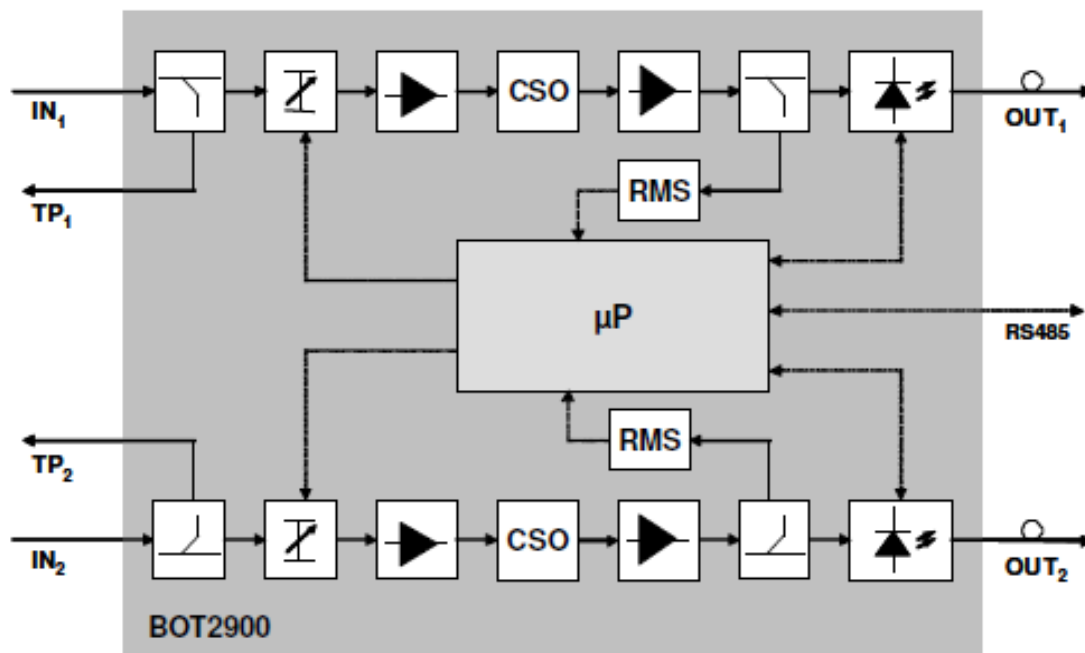

Technical specifications

Optical Properties

Wavelength		
BOT2900-1310-06	[nm]	1310 and 1310
BOT2900-C01-06/C02-06	[nm]	1271 and 1291
BOT2900-C03-06/C04-06	[nm]	1311 and 1331
BOT2900-C05-06/C06-06	[nm]	1351 and 1371
Wavelength Tolerance (for full temperature range)	[nm]	± 6 (CWDM laser)
Optical power	[dBm]	6
Laser Type		un-cooled DFB laser with optical isolator
Optical power tolerance	[dB]	± 1.0
Optical return loss	[dB]	> 35
Relative Intensity Noise RIN (JXP= 0dB)	[dBc/Hz]	< -152
Optical Connector		E2000/APC or SC/APC

Electrical Properties

RF-Frequency Range	[MHz]	47 – 1002
Flatness		
47 .. 606 MHz		±0.75
606 .. 862 MHz	[dB]	±1.0
862 .. 1002 MHz		±1.5
Performance data (grid@OMI)		C42 @ 4,1% ZIG@3,8%*)
- CSO	[dBc]	≥62 ≥62
- CTB		≥63 ≥62
Min. Input Level per Channel (for OMI = 5% p/ch)	[dBμV]	80 ±1
Test-Point input	[dB]	-20 ±1
Impedance	[Ω]	75
RF return loss	[dB]	>18 @47MHz -1.5 dB/oct, min. 15 dB
Isolation between transmitter parts	[dB]	> 60

*) based on Ziggo channel- allocation and load with overlapping CSO/CTB beats

Generic Data

Climatic Specification Operation**)		ETS 300 019-1-3, class 3.1 ETS 300 019-1-2, class 2.2 (mechanical conditions only) ETS 300 019-1-2, class 2.3 (all other conditions) ETS 300 019-1-1, class 1.1
Laser Safety according to IEC60825		Hazard Level 1M "eye-safe for normal viewing"
Product safety		EN50083-1 EN60950
EMC		EN50083-2
Power Supply Voltage	[VDC]	24
Power Consumption	[W]	< 9
Enclosure		BK-type housing, 1 slot unit
Weight	[kg]	1.3

BOT 2900

Dual Optical Forward Transmitter

***) Operation temperature range is related to a module backplane temperature between 0°C and 60°C.
This corresponds to the condition that the module is mounted on a BK sub-rack (BBT00x) with restricted total power dissipation of 90 W, no enforced cooling and with the sub-rack being operated in a temperature controlled location according to ETS 300 019-1-3, class 3.1.

Settings

Settings of operational parameters using the web-browser interface.

Setting transmitter:

Item	setting	ext.
AGC Mode	AGC on	
Desired Output Power	7.5	dBm
Activity Mode	Active	
OMI	17.65	%
RF Gain Limit	5	dB
Pilot mode	pilot on	
Fiber Length*)	0	m

*) 1310 nm version

Setting limits:

Item	setting low	setting high	ext.
RF Input Alarm	-20.0	-10.0	dBm
RF Input Warning	-18.0	-12.0	dBm
RF Gain Alarm	-5.0	5.0	dBm
RF Gain Warning	-3.0	3.0	dBm
OMI Alarm	11.79	29.63	%
OMI Warning	13.23	26.41	%
Output power Alarm	5.0	7.0	dBm
Output power Warning	5.5	6.5	dBm