

<b>Optical receiver</b>	<b>BOR1000</b>	<b>SEO 690</b>	<b>version G01 A00</b>
-------------------------	----------------	----------------	------------------------

## 1. Application

The SEO 690 is an optical broadband receiver designed for both upstream and downstream applications in modern HFC-networks in the range of 1310 ... 1550 nm. The very low noise figure of the receiver severely extends the budget of optical links while offering and extending RF-bandwidth of 7 .. 862 MHz. The SEO 690 is BK-module based and can be mounted on a 19"-module-carrier SMG 099 or in a BK die-cast-housing SMG 090.

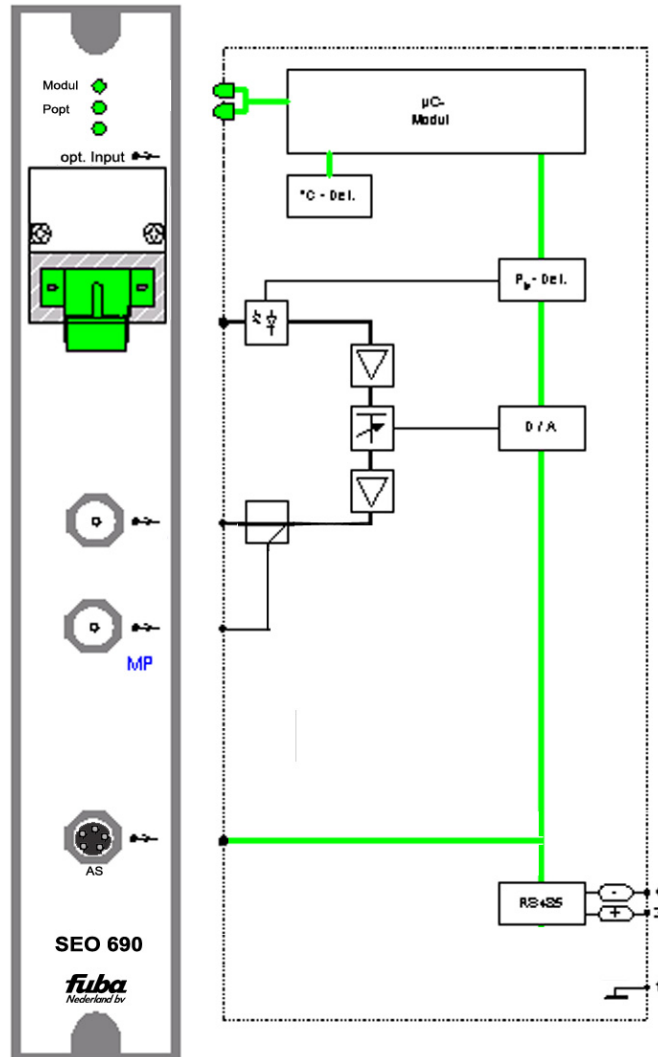

Parameter	Value	Dim.	Remark
Wavelength	1290... 1600	Nm	
Opt. Input-range	-8...+2	dBm	adjustable
Opt. Connector	E2000		
Mono-mode Fiber	9/125	μm	
Frequency range (RF)	7...862	MHz	
Output-level	81	dBμV	5% OMI
Test-point	30	dB	

## 2. Product information

### 2.1. *Functionality*

#### 2.1.1. Optical receiver

The optical receiver transforms the optical input-signal into an electrical RF-output-signal using an unique symmetrical, low-noise front-end. Variation of the optical input level is corrected electronically by means of an voltage controlled attenuator. This AGC also corrects errors due to variation of the ambient temperature.

The detected and level-controlled RF-signals are amplified and leaded to the output connector. For measurement purposes a test-point (-30 dB) is also available.

For the adjustment of the input level-range and the alarm-levels a RS 485 interface is available on pin 3+4 of the sub-D connector at the backside of the module.

#### 2.1.2. Operational high-lights

The optical receiver has the following operational parameters:

- Broadband optical input for 1310 and 1550 nm-window
- 1x RF-output, 1x Test-point, 1x RS 485, 1x Alarm output
- High signal quality
- Easy to operate
- Integrated optical power-measurement
- Integrated electrical attenuator for AGC
- Alarm-interface on mini-DIN connector
- Plug & Play

#### 2.1.3. EMS Functionality (optional)

EMS functionality is available using the RS485 interface integrated in the BK-connector (sub-D) on the backside of the module. All modules can be polled using a NEC Network Element Controller (NEC)-module. The receiver has its own Micro-controller communicating with the NEC through the BK-Bus (RS485). The following parameters are available:

- Indication of the operational status of the module
- Indication for the signal-quality
- Values of measurement and adjustment for the element-manager
- Software upgradeable
- Memory for Inventory-data

All important operational parameters of the optical receiver are constantly monitored and made available on request of the NEC. The monitor-software in the receiver detects the optical input-level and compares the value with the stored threshold-values. All threshold-values are adjustable and can be stored in the NEC and the receiver. Exceeding of threshold-values will result in the generation of alarms that are stored in the alarm-register. The alarms will be transferred to the NEC within the next polling communicating and are also available on the mini-DIN connector at the front-side of the module using potential free contacts.

Adjusting the AGC and threshold-values is possible using the NEC or laptop with dedicated software.

Also watched is the status of the cover-plate, resulting in an alarm when opening the cover of the module.

On the front-side 2 multiple-color LED's are located, indicating the different operational modes and Alarms.

Module-LED:

Module-operational mode	Description	Color
Standard operation	No alarms: $\mu$ C ok, AGC ok	green
Critical error	No optical input	off

Signal-LED (Popt):

Signal-operational mode	Description with factory adjustments *)	Color
opt. Input-level ok	$-8\text{dBm} < P_{in} < +2\text{dBm}$	green
opt. Input-level low warning	$P_{in} < -9.0\text{dBm}$	yellow
opt. Input-level high warning	$P_{in} > +3.0\text{dBm}$	yellow
no opt. Input-level	$P_{in} < -12\text{dBm}$	red

\*) All threshold-values are customer adjustable using the EMS or direct by laptop (RS 485 interface) with dedicated software.

## 2.2. Power-supply

Power is fed into the module using the BK-bus of the module-carrier. The required 24VDC is generated by the BK-power-supply module.

## 2.3. Constructive details

The SEO 690 is mounted in a standard, single BK-module that can be installed on a 19"-module-carrier (SMG 099) or die-cast housing (SMG 090).

## 2.4. Interfaces

### 2.4.1. Optical

On the front-side of the module an optical E2000 connector with protecting top is available as optical input. Other interfaces are available on request.

### 2.4.2. Electrical

One RF-output is available with 81 dB $\mu$ V RF-level (5% OMI) up to 862 MHz. The test-point output is 30 dB below the RF-output. All RF outputs are located on the front-side of the module and are IEC-female connectors, 75 ohm. The RF-output-connector has a pull-off protection that prevents the IEC-connector from unexpected disconnection. The interface for the RS485 communication is the 9 pin sub-D connector (pin 3+4) located on the backside of the module. The alarm-interface is a 5 pin mini-DIN connector located on the front-side.

### 2.4.3. Mechanical

The BK-module is connected to the sub-D-bus of the module-carrier and mechanical fixed using the 2 bolts available on the module. The module-carrier provides cooling for

the mounted BK-modules. The screwed connection insures optimal thermal contact and thus cooling of the BK-module.

## 3. Installation instruction

### 3.1. *Preparing installation*

Usually, the SEO 690 is installed in a optical-node or optical-hub as an universal receiver applicable in both optical upstream and downstream systems. Before installing the receiver, make sure the module-carrier is mounted properly and the power is switched off. Use only 24 VDC BK-power-supplies like SMN 134 for proper operation. Check all cables that will be connected to the receiver and make sure optical input-power is within the range of -8 .. +2 dBm.

### 3.2. *Mounting*

The SEO 690 is connected to the sub-D-bus of the module-carrier and mechanical fixed using the 2 bolts available on the module. Carefully aiming and plugging-in the module without using any force!

### 3.3. *Connections*

First remove the protection of the optical connector on the receiver and plug-in the pig-tail of the input-fiber. Next plug-in the IEC-connector of the coaxial output-cable and switch-on the power-supply. If the optical power is within the configured range, no additional adjustments are necessary and all LED's will color green. The RF output-level will also be within range, provided the OMI is in accordance with the system calculation.

### 3.4. *Configuration*

The SEO 690 is factory pre-configured plug-and-play. Only in special operational circumstances and for test-purposes it can be meaningful to configure operational parameters manually. For this purpose connect the service-PC (laptop) to the management-bus (sub-D connector) using the RS-485 adapter.

<i>Parameter</i>	<i>Factory adjustment</i>	<i>adjustment range</i>
<i>Optical level</i>		
<i>to high (warning)</i>	$> +3.0 \text{ dBm}$	$-20 \dots +5 \text{ dBm}$
<i>to low (warning)</i>	$< -9.0 \text{ dBm}$	$-20 \dots +5 \text{ dBm}$
<i>no input (alarm)</i>	$< -12.0 \text{ dBm}$	$-20 \dots +5 \text{ dBm}$
Hysteresis	0.5 dB	



## 4. Technical specifications

Type	SEO 690				
Ordering number	BOR 1000				
Measure value	Dim.	Min.	Typ.	Max.	Remark
Wavelength	nm	1290		1600	
Opt. input-power range	dBm	-8		+2	1)
Opt. return loss	dB	40	45		
AGC range	dB	-10		+10	optical
AGC tolerance	dB		±0.5		
RF-output					
Frequency range	MHz	7		862	
Output level	dBμV		81		1), 2)
Flatness	dB		±0.5	±0.8	
Receiver noise	pA√/Hz		4	5	at -8 dBm
Detector responsiveness	A/W	0,9		1	at 1550 nm
CSO (CENELEC 42)	dBc		60		
CTB (CENELEC 42)	dBc		63		
Flatness test-point	dB		±1		
Attenuation test-point	dB		30		
Connectors			IEC		
Return-loss output	dB		20		3)
Impedance output	ohm		75		
Supply Voltage Pin 5	VDC	22.8	24	25.2	
Current Pin 5 incl. μC-Module	mA	150	160		
Isolation (EN 50083 part 2)	dB	75			
Radiation (EN 50083 part 2)	dBpW			20	
Operational temperature-range	°C	-20		+60	
Operational lifetime	Year	19,5			5900 FIT
Weight	kg		1		
Dimensions (L x H x W)	mm	40 x 250 x 100			1 unit-width
Opt. connector	E2000				
Norms and allowance	EN50083 (CE), 1 TR 9				

- 1) at 1550nm wavelength and 5% OMI
- 2) Output level at 7...862MHz
- 3) >20dB at 47MHz, -1dB/Okt (min. 16dB)

## 4.1. Pin connections:

### Sub-D connector

Pin 1	Ground
Pin 2	optional external redundant 6,5 ... 8 VDC $\mu$ C supply: note for more than 8 VDC there might be a permanent damage of the device, for input voltages below 6 VDC, a switching diode prevents any current flow into the device
Pin 3	RS-485 (+)
Pin 4	RS-485 (-)
Pin 5	24V
Pin 6	$\mu$ C input port (optional), 1 MOhm pull up to 5 VDC
Pin 7	NC
Pin 8	$\mu$ C input port (optional)
Pin 9	$\mu$ C input port (optional), 22 kOhm pull up to 4.1 V

### Mini-Din connector

Pin 1	Popt in	normal high	alarm low *)
Pin 2	NC		
Pin 3	Ground		
Pin 4	Opt. threshold (B)	normal high	alarm low
Pin 5	Popt in (A2)	normal high	alarm low

high = 7,5 V  
low = 0 V

\*) Threshold +/- 1,5 dB, Hysteresis 0,5 dB