



VECTOR



broadband distribution node

GAMMA 0

INTRODUCTION

GAMMA is a broadband distribution node designated to be used as a compact, multiport optical or distribution node in HFC network. Modern technology applied in GAMMA supports very high output RF levels with low intermodulation distortions while consuming little power. GAMMA used as a compact optical node allows full redundancy and AGC in forward path as well as redundancy or segmentation in reverse path.

GAMMA with its modular design allows flexible configuration and step-by-step development of the system. The use of universal plug-in modules leads to convenient maintenance and operational costs reduction.

Highly adjustable and configurable reverse path in GAMMA can be either active or passive. Ingress switch and ingress filter plug-in modules are helpful when eliminating problems with reverse path interferences. Availability of DWDM & CWDM technology enables implementation of modern concepts of optical access network.

GAMMA can be powered locally up to 15A or remotely with 12A current passing by each RF port. Multistage overvoltage protection of all RF ports increases durability of the appliance resulting in higher reliability of the network.

GAMMA O is prepared to work with different Network Management Systems and has the facility to be remotely monitored and controlled. It enables an operator to:

- control three-state ingress switch and receiver redundancy configuration
- monitor input/output optical power of the receiver/transmitter
- supervise AC and DC voltage as well as DC current
- check external contacts and temperature inside the housing

More information can be found in "NMS transponders for distribution node GAMMA and telecommunication amplifier BETA" data sheet.

Available in 6 standard versions with outstanding IP67 compact housing, GAMMA is the optimum solution for HFC network.

FEATURES

- Forward path redundancy
- Reverse path redundancy or segmentation
- Network Management System ready
- AGC controlled by pilot tone or optical power
- Separate RF slope and level control
- Remote or local powering, mains powering and low power consumption
- IP 67 compact housing

GAMMA 08 ■ - ■ ■ A - ■ ■ 8 / ■ ■ /

- **type**
O - optical
- **forward bandwidth**
8 - up to 862MHz
- **powering**
X - remote from any RF port or local
M - mains powering
- **the number of RF outputs**
1 - 1 output
2 - 2 outputs
3 - 3 outputs
- **the number of output hybrids**
1 - 1 hybrid
2 - 2 hybrids
3 - 3 hybrids
- **mainboard type**
A - type A
- **output stage**
AE - GaAs Power Doubler
AF - GaAs Push Pull
- **connectors**
8 - PG11 input / PG11 output
- **mainboard configuration**
empty - 5 ÷ 65MHz reverse bandwidth
/42/ - 5 ÷ 42MHz reverse bandwidth
/30/ - 5 ÷ 30MHz reverse bandwidth

broadband distribution node GAMMA O

PARAMETERS

GAMMA 08X-11A-AE8 **GAMMA 08X-11A-AE8/42/** **GAMMA 08X-11A-AE8/30/**
GAMMA 08M-11A-AE8 **GAMMA 08M-11A-AE8/42/** **GAMMA 08M-11A-AE8/30/**

PARAMETER	VALUE	COMMENT
Wavelength [nm]	1100 ÷ 1600	
Optical input power range [dBm]	-5 ÷ +2	
Equivalent input noise [pA/√Hz]	≤ 8	
Optical connector	SC/APC	Others on request
Optical power test point [V/mW]	1 ± 0.1	
RF level at the output of the OFR [dBμV]	78 ± 1	4.5% OMI/channel, 0dBm input optical power
Optical power indicator [dBm]	- 5	Green – optical power > -5dBm Red – optical power < -5dBm
Forward bandwidth [MHz]	47...85 ÷ 862	DF diplex filters
Maximum output RF level [dBμV]	117 ± 1	0dBm input optical power, 4.5% OMI/channel
Flatness [dB]	±0.75	DF diplex filters, AT 800 and ATG 800 jumpers
Slope [dB]	±1	DF diplex filters, AT 800 and ATG 800 jumpers
CNR [dBc]	56	4.5%OMI/ channel, 10dB passive optical loss
Output level typ. [dBμV]		According to EN 50083-3; 9dB interstage equalizer, 42 CENELEC carriers, optical transmitter distortions not included
CTB ≤ -60dBc	114	
CSO ≤ -60dBc	112	
Reverse bandwidth [MHz]	5 ÷ 30...65	DF diplex filters
Reverse gain [dB]	26 ± 0.75	Port 4 to ORT reverse transmitter; DF diplex filters, ATG 800 jumpers, RCG 04 configuration module, RAG amplifier
Reverse noise figure [dB]	≤7	DF diplex filters, ATG 800 jumpers, RCG 04 configuration module and RAG amplifier
NPR [dBc]	≤-60	RAG amplifier, 27dBμV/Hz signal @ 60MHz
HUM modulation @ 12A [dBc]	5 ÷ 15MHz	≤-55
(remote powering)	15 ÷ 65MHz	≤-60
	85 ÷ 862MHz	≤-60
HUM modulation		≤-70
		187 ÷ 253VAC, 50 ÷ 60Hz (mains powering)
RF return loss [dB]		≤-18
		f ≤ 40MHz; f > 40MHz: +1.5/oct
Test point @ input [dB]	-20 ± 1	Relative to the output of OFR receiver
Test points @ outputs @ reverse inputs	-20 ± 1	Directional coupler
Number of RF ports/connectors type	2 / PG11	Port 1 – reverse auxiliary input 5 ÷ 210MHz for ORT transmitter
AC voltage range [V]	remote powering	35 ÷ 65
	mains powering	187 ÷ 253
		AC 50 ÷ 60Hz
Maximum current for AC IN port [A]		15
		Power insertion port (remote powering)
Maximum current for RF port [A]		12
		All RF ports, except Port 1 (remote powering)
AC current consumption [mA]	35 VAC	850
(remote powering)	48 VAC	660
	65 VAC	510
		RAG amplifier and OFR receiver
AC current consumption [mA]	187 VAC	197
(mains powering)	230 VAC	161
	253 VAC	150
		RAG amplifier and OFR receiver
AC power consumption [W]		25
(remote powering)		26
		RAG amplifier and OFR receiver RAG amplifier, OFR receiver and ORT transmitter
AC power consumption [W]		26
(mains powering)		27
		RAG amplifier and OFR receiver RAG amplifier, OFR receiver and ORT transmitter
Protection class IP		IP 67
Operating ambient temperature range [°C]		-40 ÷ +60
MTBF [years]		>30
		@25°C, without ORT transmitter
Dimensions (W x L x H) [mm]		245 x 195 x 125
Weight [kg]		4.3

broadband distribution node GAMMA 0

PARAMETERS

GAMMA 08X-22A-AE8

GAMMA 08X-22A-AE8/42/

GAMMA 08X-22A-AE8/30/

GAMMA 08M-22A-AE8

GAMMA 08M-22A-AE8/42/

GAMMA 08M-22A-AE8/30/

PARAMETER	VALUE	COMMENT
Wavelength [nm]	1100 ÷ 1600	
Optical input power range [dBm]	-5 ÷ +2	
Equivalent input noise [pA/√Hz]	≤ 8	
Optical connector	SC/APC	Others on request
Optical power test point [V/mW]	1 ± 0.1	
RF level at the output of the OFR [dBμV]	78 ± 1	4.5% OMI/channel, 0dBm input optical power
Optical power indicator [dBm]	- 5	Green – optical power > -5dBm Red – optical power < -5dBm
Forward bandwidth [MHz]	47...85 ÷ 862	DF diplex filters
Maximum output RF level [dBμV]	2 x 117 ± 1	0dBm input optical power, 4.5% OMI/channel
Flatness [dB]	±0.75	DF diplex filters, AT 800 and ATG 800 jumpers
Slope [dB]	±1	DF diplex filters, AT 800 and ATG 800 jumpers
CNR [dBc]	56	4.5%OMI/ channel, 10dB passive optical loss
Output level typ. [dBμV]		According to EN 50083-3; 9dB interstage equalizer, 42 CENELEC carriers, optical transmitter distortions not included
CTB ≤ -60dBc	114	
CSO ≤ -60dBc	112	
Reverse bandwidth [MHz]	5 ÷ 30...65	DF diplex filters
Reverse gain [dB]	23 ± 0.75	Ports 3,4 to ORT reverse transmitter; DF diplex filters, ATG 800 jumpers, RCG 03 configuration module, RAG amplifier
Reverse noise figure [dB]	≤10	DF diplex filters, ATG 800 jumpers, RCG 03 configuration module and RAG amplifier
NPR [dBc]	≤-60	RAG amplifier, 27dBμV/Hz signal @ 60MHz
HUM modulation @ 12A [dBc]	5 ÷ 15MHz	≤-55
(remote powering)	15 ÷ 65MHz	≤-60
	85 ÷ 862MHz	≤-60
HUM modulation		≤-70
		187 ÷ 253VAC, 50 ÷ 60Hz (mains powering)
RF return loss [dB]	≤-18	f≤40MHz; f>40MHz: +1.5/oct
Test point @ input [dB]	-20 ± 1	Relative to the output of OFR receiver
Test points @ outputs @ reverse inputs	-20 ± 1	Directional coupler
Number of RF ports/connectors type	3 / PG11	Port 1 – reverse auxiliary input 5 ÷ 210MHz for ORT transmitter
AC voltage range [V]	remote powering mains powering	35 ÷ 65 187 ÷ 253
		AC 50 ÷ 60Hz
Maximum current for AC IN port [A]		15
		Power insertion port (remote powering)
Maximum current for RF port [A]		12
		All RF ports, except Port 1 (remote powering)
AC current consumption [mA]	35 VAC	1500
(remote powering)	48 VAC	1150
	65 VAC	850
AC current consumption [mA]	187 VAC	275
(mains powering)	232 VAC	232
	253 VAC	217
AC power consumption [W]		40
(remote powering)		42
		RAG amplifier and OFR receiver RAG amplifier, OFR receiver and ORT transmitter
AC power consumption [W]		40
(mains powering)		41
		RAG amplifier and OFR receiver RAG amplifier, OFR receiver and ORT transmitter
Protection class IP		IP 67
Operating ambient temperature range [°C]		-40 ÷ +60
MTBF [years]		>30
		@25°C, without ORT transmitter
Dimensions (W x L x H) [mm]		245 x 195 x 125
Weight [kg]		4.3

broadband distribution node GAMMA O

PARAMETERS

GAMMA O8X-33A-AF8
GAMMA O8M-33A-AF8

GAMMA O8X-33A-AF8/42/
GAMMA O8M-33A-AF8/42/

GAMMA U8X-33A-AF8/30/
GAMMA U8M-33A-AF8/30/

PARAMETER	VALUE	COMMENT
Wavelength [nm]	1100 ÷ 1600	
Optical input power range [dBm]	-5 ÷ +2	
Equivalent input noise [pA/√Hz]	≤ 8	
Optical connector	SC/APC	Others on request
Optical power test point [V/mW]	1 ± 0.1	
RF level at the output of the OFR [dBμV]	78 ± 1	4.5% OMI/channel, 0dBm input optical power
Optical power indicator [dBm]	- 5	Green – optical power > -5dBm Red – optical power < -5dBm
Forward bandwidth [MHz]	47...85 ÷ 862	DF diplex filters
Maximum output RF level [dBμV]	3 x 117 ± 1	0dBm input optical power, 4.5% OMI/channel
Flatness [dB]	±0.75	DF diplex filters, AT 800 and ATG 800 jumpers
Slope [dB]	±1	DF diplex filters, AT 800 and ATG 800 jumpers
CNR [dBc]	56	4.5%OMI/ channel, 10dB passive optical loss
Output level typ. [dBμV]		According to EN 50083-3; 9dB interstage equalizer, 42 CENELEC carriers, optical transmitter distortions not included
CTB ≤ -60dBc	110	
CSO ≤ -60dBc	110	
Reverse bandwidth [MHz]	5 ÷ 30...65	DF diplex filters
Reverse gain [dB]	21 ± 0.75	Ports 2,3,4 to ORT reverse transmitter; DF diplex filters, ATG 800 jumpers, RCG 01 configuration module, RAG amplifier
Reverse noise figure [dB]	≤12	DF diplex filters, ATG 800 jumpers, RCG 01 configuration module and RAG amplifier
NPR [dBc]	≤-60	RAG amplifier, 27dBμV/Hz signal @ 60MHz
HUM modulation @ 12A [dBc]	5 ÷ 15MHz	≤-55
(remote powering)	15 ÷ 65MHz	≤-60
	85 ÷ 862MHz	≤-60
HUM modulation		≤-70
RF return loss [dB]		187 ÷ 253VAC, 50 ÷ 60Hz (mains powering)
Test point @ input [dB]	≤-18	f ≤ 40MHz; f > 40MHz: +1.5/oct
Test points @ outputs @ reverse inputs	-20 ± 1	Relative to the output of OFR receiver
Number of RF ports/connectors type	-20 ± 1	Directional coupler
AC voltage range [V]	4 / PG11	Port 1 – reverse auxiliary input 5 ÷ 210MHz for ORT transmitter
remote powering	35 ÷ 65	
mains powering	187 ÷ 253	AC 50 ÷ 60Hz
Maximum current for AC IN port [A]	15	Power insertion port (remote powering)
Maximum current for RF port [A]	12	All RF ports, except Port 1 (remote powering)
AC current consumption [mA]	1500	
(remote powering)	35 VAC	1150
	48 VAC	850
	65 VAC	
AC current consumption [mA]	275	
(mains powering)	187 VAC	232
	230 VAC	217
	253 VAC	
AC power consumption [W]	40	RAG amplifier and OFR receiver
(remote powering)	42	RAG amplifier, OFR receiver and ORT transmitter
AC power consumption [W]	40	
(mains powering)	41	RAG amplifier and OFR receiver
Protection class IP	IP 67	RAG amplifier, OFR receiver and ORT transmitter
Operating ambient temperature range [°C]	-40 ÷ +60	
MTBF [years]	>30	@25°C, without ORT transmitter
Dimensions (W x L x H) [mm]	245 x 195 x 125	
Weight [kg]	4.3	

BLOCK DIAGRAMS

GAMMA 08X-11A-AE8,
GAMMA 08X-11A-AE8/42/,
GAMMA 08X-11A-AE8/30/,
GAMMA 08M-11A-AE8,
GAMMA 08M-11A-AE8/42/,
GAMMA 08M-11A-AE8/30/

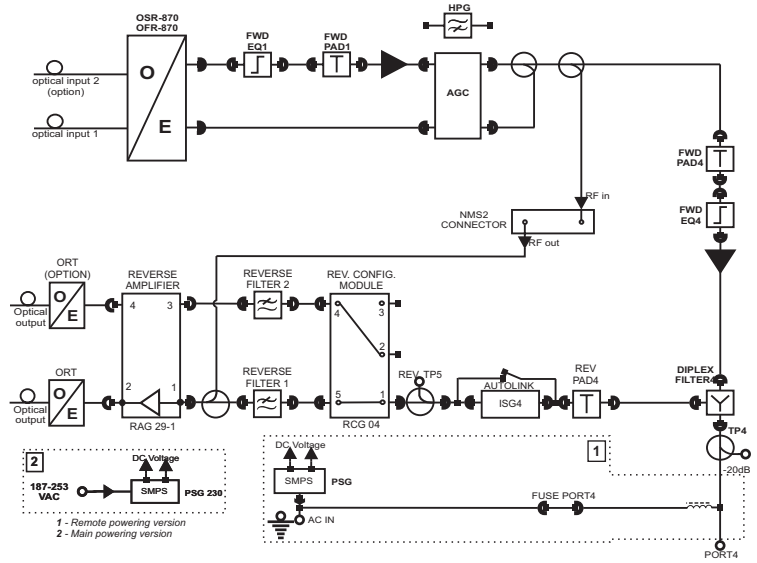

GAMMA 08X-22A-AE8,
GAMMA 08X-22A-AE8/42/,
GAMMA 08X-22A-AE8/30/,
GAMMA 08M-22A-AE8,
GAMMA 08M-22A-AE8/42/,
GAMMA 08M-22A-AE8/30/

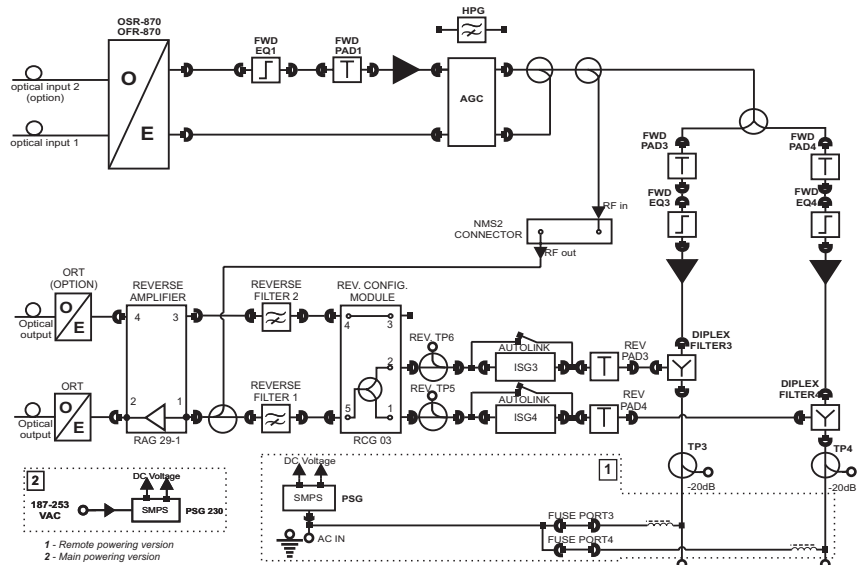

GAMMA 08X-33A-AF8,
GAMMA 08X-33A-AF8/42/,
GAMMA 08X-33A-AF8/30/,
GAMMA 08M-33A-AF8,
GAMMA 08M-33A-AF8/42/,
GAMMA 08M-33A-AF8/30/

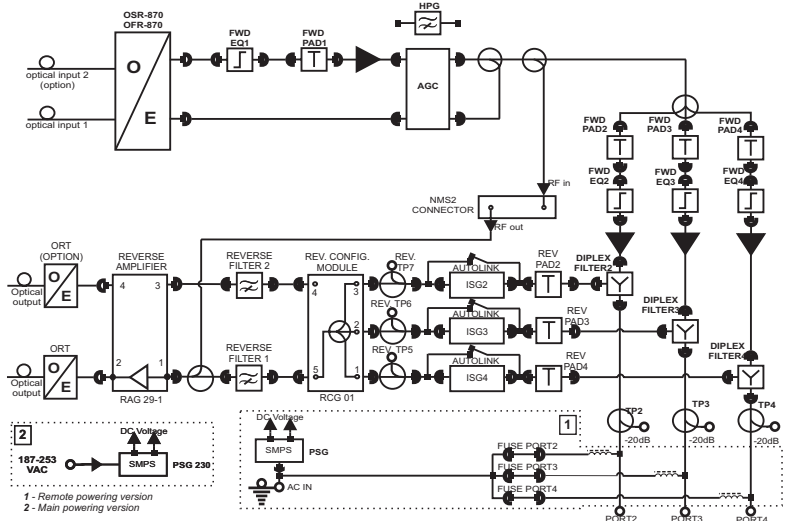

Reverse amplifier modules

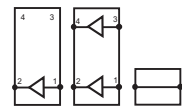

Reverse configuration modules

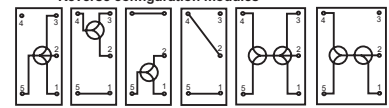

Specifications are subject to change without notice.
03.12.18 page 6 of 6