



VECTOR



γ

**operation manual
broadband distribution node
GAMMA 0**

© October 2003 by
VECTOR Sp. z o.o.

All rights reserved.
No part of this book may be
reproduced in any form or by any
means, without permission in
writing from VECTOR.

TABLE OF CONTENTS

1. GENERAL INFORMATION	5
1.1. Introduction to manual.....	5
1.2. General installation conditions	5
1.3. Receiving the unit and inspection	5
1.4. Storage	5
2. FUNCTIONAL DESCRIPTION	6
2.1. General characteristic	6
2.2. Block diagram	7
2.3. Forward path	8
2.3.1. Optical receiver module.....	8
2.3.2. Adjustment of input level	8
2.3.3. Optional automatic gain control AGC.....	8
2.3.4. Optional automatic slope and gain control ASC	9
2.3.5. Forward path amplifier.....	9
2.3.6. Interstage adjustment.....	9
2.3.7. Outputs.....	9
2.3.8. Test points.....	9
2.4. Reverse path	9
2.4.1. Reverse path configuration	9
2.4.2. Diplex filters.....	10
2.4.3. Reverse amplifier	10
2.4.4. Signal adjustment in reverse path.....	10
2.4.5. Test points.....	11
2.5. Powering.....	11
2.6. NMS monitoring system.....	12
2.7. Inside overview	12
2.8. Housing	14
3. MOUNTING.....	15
3.1. Preparing for node installation.....	15
3.2. Installation.....	15
3.3. Grounding	15
3.4. Cable connection.....	15
4. CONFIGURATION AND SETUP	17
4.1. Fusing.....	17
4.2. Configuration of the optical node	18
4.2.1. Forward path plug-in modules.....	18
4.2.2. Reverse path plug-in modules	18
4.3. Set-up and adjustment.....	18
4.3.1. Forward path	19
4.3.1.1. Automatic gain control AGC.....	19
4.3.2. Reverse path	21
4.3.2.1. Reverse path set-up and adjustment.....	23

4.4. Cover closing	24
5. UPGRADING GAMMA OPTICAL NODE	25
5.1.1. Redundant optical receiver	25
5.1.2. Additional gain in reverse path	27
5.1.3. Optional single tone reference generator module	27
5.1.4. External RF input 5 ÷ 210MHz for reverse path	28
6. GAMMA OPTICAL NODE TECHNICAL SPECIFICATION	29
6.1. GAMMA O8X-33A-AF8	29
6.2. GAMMA O8X-22A-AE8	30
6.3. GAMMA O8X-11A-AE8	31
7. PLUG-IN MODULES TECHNICAL SPECIFICATION	32
7.1. OFR 870-xxx – Optical receiver module	32
7.2. OSR 870-xxx –Optical receiver with redundancy module	33
7.3. ORT F1310-xxx – FP 1310 nm optical transmitter module	34
7.4. ORT D1310-xxx – DFB 1310 nm optical transmitter module	35
7.5. ORT 3D1310-xxx – DFB 1310 nm optical transmitter module	36
7.6. ORT D1550-xxx – DFB 1550 nm optical transmitter module	36
7.7. ORT DCXXX-xxx – DFB CWDM optical transmitter module	38
7.8. AGC xxx-x – Automatic gain control module	39
7.9. AGC 000-x – Automatic gain control module	39
7.10. ASC 549-6 – Automatic slope and gain control module controlled by pilot tone	39
7.11. RCA – Output module for coaxial reverse output	40
7.12. CKG 01 – Optical node conversion kit	40
7.13. RAG 29-1 xx – Reverse amplifier module for single reverse path	40
7.14. RAG 29-2 – Reverse amplifier module for dual reverse path	40
7.15. RCG xx – Reverse configuration modules	41
7.16. ISG 65 – Ingress switch module	41
7.17. OLP xx – Band-pass filter module for optical reverse transmitter	42
7.18. OLPA xx – Active band-pass filter module for optical reverse transmitter ..	42
7.19. HPG xx – High-pass filter module	42
7.20. DF xxA – Diplex filter module	42
7.21. EQ 8xx – Fixed equalizer module for forward path	43
7.22. EQSG 805 ÷ EQSG 811 – Forward path fixed system equalizer module for optimizing the characteristic of cascaded GAMMA	43
7.23. CS 8xx – Cable simulator module	44
7.24. AT 800 – Jumper for forward path	44
7.25. ATG 8xx/ATG 075 – Fixed attenuator and 75 Ohm terminator modules	44
7.26. REQ xx – Equalizer module for reverse path	44

7.27. RJP – Jumper for reverse path.....	44
7.28. RHP xx – High-pass filter module for reverse path	44
7.29. RRG xxx – Single tone reference generator module	45
7.30. PSG 65 – Switch mode power supply (SMPS) module 35÷65 VAC	45
7.31. PSG 90 – Switch mode power supply (SMPS) module 40÷90 VAC	45
APPENDIX 1. CHANGING THE BANDWIDTH OF GAMMA OPTICAL NODE..	46
APPENDIX 2. OPTICAL ADAPTERS REPLACEMENT	48

1. GENERAL INFORMATION

1.1. Introduction to manual

This manual contains information needed to properly install and operate GAMMA optical node manufactured by VECTOR.

The instructions in this manual do not cover all details on the equipment it supports, nor do they provide solutions for all circumstances that could arise during equipment maintenance. The instructions included are intended to be performed by experienced CATV service technicians only.

The information in this manual is subject to change without notice.

If you have any questions or remarks regarding this publication, please contact

VECTOR
ul. Krzemowa 6
81-577 Gdynia
POLAND
tel.: +48 58 / 77-17-000
fax: +48 58 / 77-17-100
e-mail: vector@vector.com.pl

or your nearest VECTOR representative.

1.2. General installation conditions

VECTOR guarantees proper working of GAMMA optical node if operating in accordance with the instructions in this manual. All instructions in this manual should be reviewed carefully before any procedures are performed.

VECTOR is not responsible for any personal injuries or equipment damage caused by improper installation or operation of the unit.

Modifications or alterations of VECTOR products (including but not limited to installation of non-VECTOR equipment) except as performed by VECTOR, will void the warranty.

ATTENTION!

Before installing the equipment it is strongly recommended to read this manual carefully.

1.3. Receiving the unit and inspection

Before shipment, VECTOR packs and inspects all items carefully. Nevertheless, damage may occur during shipment. Inspection must be performed when unpacking the equipment before installation (do not destroy shipping cartons until installation is complete, if possible retain it for future equipment reshipment or storage if needed).

Inspect unit for damaged housing, cover or input/output ports.

If any problems arise during inventory or if for any reason equipment needs to be returned to manufacturer, please contact VECTOR's sales office for assistance.

1.4. Storage

GAMMA optical node can be stored without any degradation of parameters during 18 months after manufacturing. Standard atmospheric conditions for storing accordingly to IEC 68.1 norm: temperature. 15 ÷ 35°C, humidity 25 ÷ 70%, pressure 860 ÷ 1060 hPa.

2. FUNCTIONAL DESCRIPTION

2.1. General characteristic

There are available the following GAMMA optical node models:

- **GAMMA O8X-11A-AE8** – one balanced individually driven output using GaAs FET Power Doubler device, 5÷65/85÷862 bandwidth;
- **GAMMA O8X-22A-AE8** – two balanced individually driven outputs using GaAs FET Power Doubler devices, 5÷65/85÷862 bandwidth;
- **GAMMA O8X-33A-AF8** – three balanced individually driven outputs using GaAs FET Push-Pull devices, 5÷65/85÷862 bandwidth

- **GAMMA O8X-11A-AE8/30/** – one balanced individually driven output using GaAs FET Power Doubler device, 5÷30/47÷862 bandwidth;
- **GAMMA O8X-22A-AE8/30/** – two balanced individually driven outputs using GaAs FET Power Doubler devices, 5÷30/47÷862 bandwidth;
- **GAMMA O8X-33A-AF8/30/** – three balanced individually driven outputs using GaAs FET Push-Pull devices, 5÷30/47÷862 bandwidth

- **GAMMA O8X-11A-AE8/42/** – one balanced individually driven output using GaAs FET Power Doubler device, 5÷42/54÷862 bandwidth;
- **GAMMA O8X-22A-AE8/42/** – two balanced individually driven outputs using GaAs FET Power Doubler devices, 5÷42/54÷862 bandwidth;
- **GAMMA O8X-33A-AF8/42/** – three balanced individually driven outputs using GaAs FET Push-Pull devices, 5÷42/54÷862 bandwidth

GAMMA optical node has been designed for application in distribution networks of modern bi-directional CATV and telecommunication systems. Due to high quality, reliability, monitoring-readiness and up-to-date technology, using GAMMA optical nodes guarantees high availability of network as required for interactive services. GaAs-FET forward path output stages provide extremely high output signal's level, while reducing optical node's power consumption at the same time. Together with wide range of supply voltage it reduces operational and powering costs significantly, thus making the optical node very effective. GAMMA can be powered through any of the RF ports or additional local powering port (Power Inserter); the power supply section accepts sine and quasi-square wave inputs from the range 35 ÷ 65 VAC and generates all necessary DC voltages required by the optical node's electronics.

GAMMA allows flexible reverse path configuration due to plug-in configuration modules, diplex filters, reverse path amplifier or jumper and remotely controlled reverse path switch.

Optical node is ready for status monitoring – interfaces installed inside the housing are available for connection to an NMS modem. The modem will enable the control of amplifier's main parameters and tools to solve reverse path noise and ingress problems.

GAMMA optical nodes meet CENELEC technical requirements EN 50083 and comply with EN 50083-3 at the same guaranteeing electromagnetic compatibility.

2.2. Block diagram

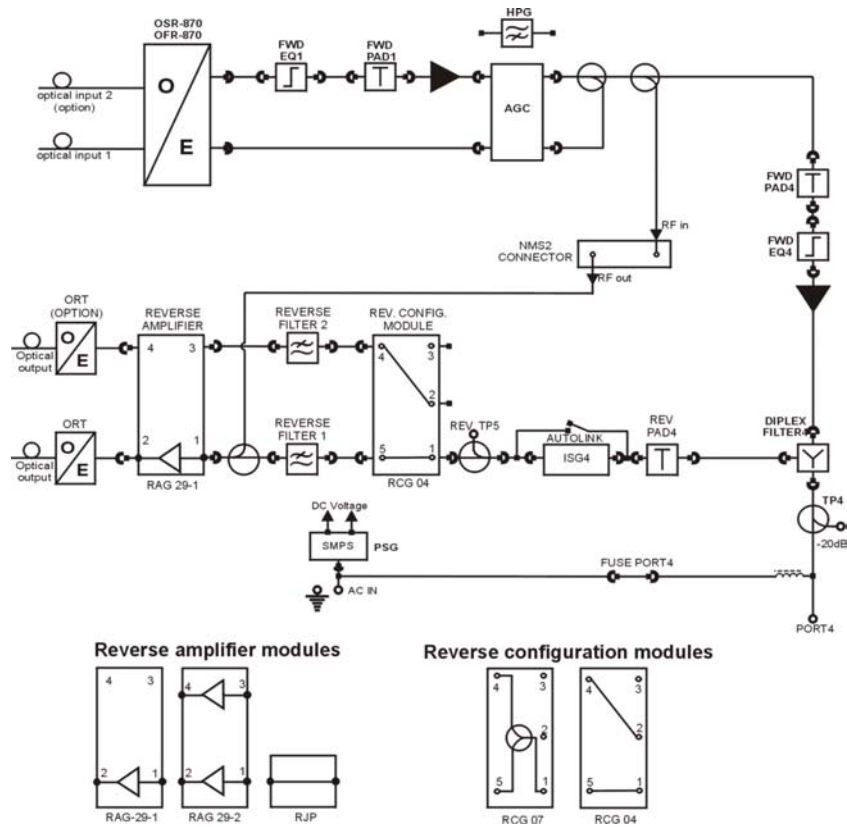

Fig. 1. GAMMA O8X-11A-AE8 optical node functional block diagram.

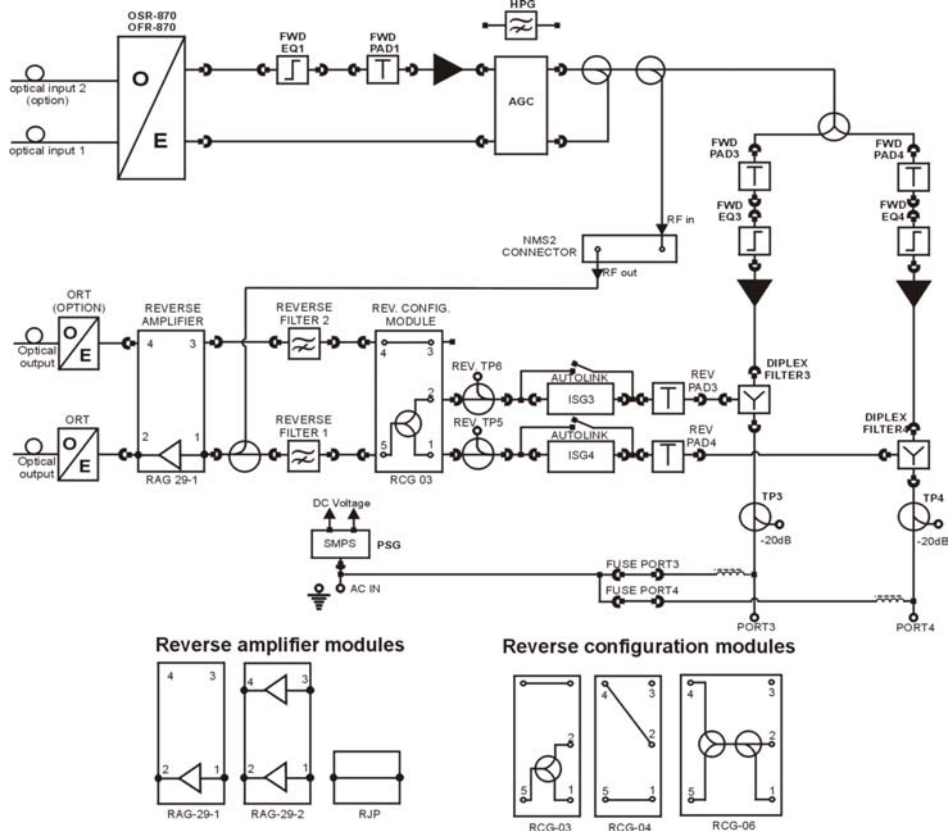

Fig. 2. GAMMA O8X-22A-AE8 optical node functional block diagram.

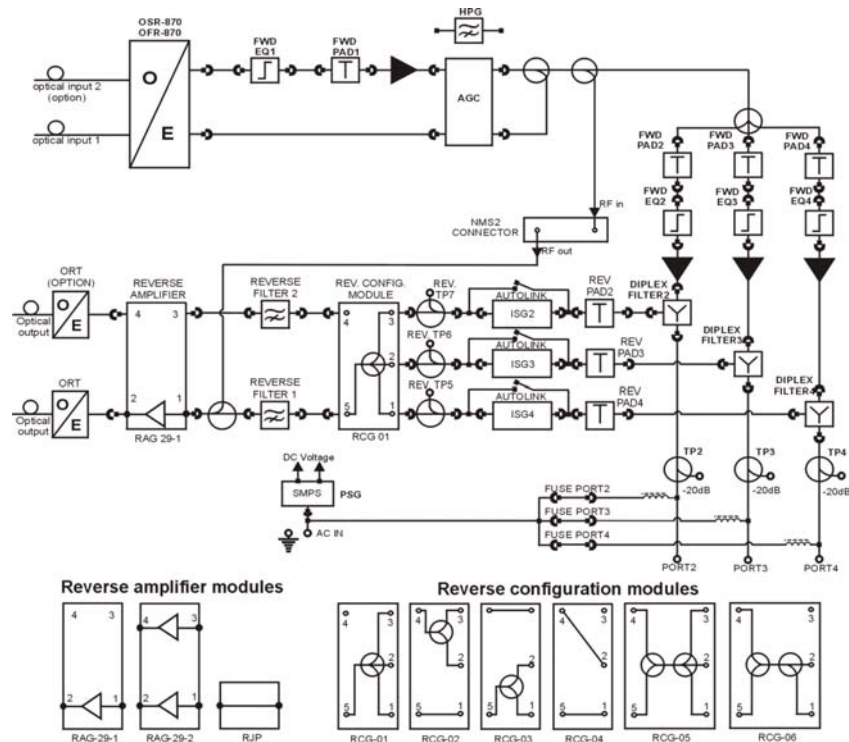

Fig. 3. GAMMA O8X-33A-AF8 optical node functional block diagram.

2.3. Forward path

The forward path section provides conversion of the incoming optical signal to the RF signal and its amplification and further distribution using coaxial cable. Installation of optical reverse transmitters enables backward optical transmission in reverse path from optical node. To trace signal flow through the unit follow the functional block diagram.

2.3.1. Optical receiver module

The optical signal enters the node through optical receiver module **OFR** or **OSR**. At the output of this module the RF signal is provided.

2.3.2. Adjustment of input level

Optical input signal is being converted in the optical receiver module to RF signal which then enters the preamplifier through series plug-in attenuator and equalizer in order to establish proper level and flat characteristic at the input stage of the node. The input equalizer can be used to fight against roll-off problem in optical links. Fixed attenuator modules **ATG 8xx** and fixed equalizer modules **EQ 8xx** are available for this adjustment.

2.3.3. Optional automatic gain control AGC

Optional AGC module **AGC xxx-x** enables automatic gain control determined by the level of the pilot signal in order to maintain constant signal output level. AGC circuit monitors the pilot carrier and depending on its level changes amplifier's gain. For optical node alternatively optional AGC module **AGC 000-x** enables automatic gain control determined by the level of the optical input signal to optical receiver.

2.3.4. Optional automatic slope and gain control ASC

Optional ASC module **ASC 549-6** enables automatic slope and gain control determined by pilot tone level @ 549 MHz.

2.3.5. Forward path amplifier

Modern GaAs-FET technology is used in GAMMA distribution amplifier. The input and output stages are made using GaAs-FET devices. GaAs-FET technology enables extremely high output signal's level, while reducing power consumption comparing to standard Silicone bipolar technology. Low noise input stage provides low noise figure of the node leading to very good carrier to noise ratio CNR. The very high gain (38dB) is consistent with the high output level.

2.3.6. Interstage adjustment

The interstage position provides the possibility to adjust output signal's level and tilt using plugged-in modules **ATG 8xx** and **EQ 8xx**. If interstage adjustment is not used, jumper module **AT 800** must be installed instead of equalizer module for proper operation.

Interstage tilt allows increasing amplifier's output level without degradation of intermodulation distortions. On the other hand, interstage attenuation allows lowering node gain while keeping high CNR. The noise figure of the GAMMA node is almost kept without degradation.

2.3.7. Outputs

There are three possible output's configurations depending on the model of the optical node:

- one balanced individually driven output – GAMMA O8X-**11A**-AE8,
- two balanced individually driven outputs – GAMMA O8X-**22A**-AE8.
- three balanced individually driven outputs – GAMMA O8X-**33A**-AF8.

The output diplex filters follow the output stages. The diplex filters combine the forward RF signal and the reverse RF signal.

2.3.8. Test points

Test points -20dB, with typical F connectors are provided at the input and at all outputs of the distribution amplifier: bi-directional test point is available at the input and directional test points at all outputs. Easy accessible F connectors enable precise measurements of signal level.

ATTENTION!

The frequency response of bi-directional test point depends very much on the actual return loss of the connected load.

2.4. Reverse path

2.4.1. Reverse path configuration

The reverse path offers a lot of flexibility in its configuration due to reverse signal configuration modules **RCG xx** installed in *REV CONFIG MODULE* socket. Typically there is only one reverse output with reverse amplifier **RAG 29-1**, reverse configuration module **RCG 04** in GAMMA O8X-11A-AE8, **RCG 03** in GAMMA O8X-22A-AE8 or **RCG 01** in GAMMA O8X-33A-AF8 and optical reverse transmitter **ORT**. However, dual reverse channel might be installed in GAMMA. In this case dual reverse amplifier **RAG 29-2** is required as well as **RCG xx** (where xx is 02, 04, 05 or 06) and two optical transmitters **ORT**. Note, that if dual channel reverse path is enabled **RHP xx** or **RJP** modules must be placed in *REV FILTER 1* and *REV FILTER 2* sockets. If only one channel is used, one of these modules must be installed in *REV FILTER 1* sockets. There is a number of possible connections between inputs and outputs of reverse path depending on used **RCG xx** module.

Solution like this offers the users a lot of flexibility. If amplification in reverse path is not required **RAG 29-1** should be replaced by **RJP** module. Two **RJP** modules are necessary in order to replace **RAG 29-2**. If more bandwidth is required in downstream an additional external input $5 \div 210\text{MHz}$ is provided on **ORT** module. This input is available only for transmitter placed in **ORT 1** position (see 5.1.4)

By default RCG 03 module is installed in GAMMA O8M-22A-AE8, while RCG 01 is installed in GAMMA O8X-33A-AF8. More information about reverse path configuration one can find in chapters 4.2.2 and 4.3.2.

Location of all elements is presented in the Fig. 6

Filters can be installed in **REV FILTER 1** and **REV FILTER 2** sockets to reduce ingress in the reverse path. Typically high- pass filter **RHP 15** is installed in this place in order to cut off the frequency range $5 \div 15\text{MHz}$ where the ingress level is very high. However, it is possible to cut off different frequency ranges depending on installed filter (e.g. 27MHz notch filter for reject noise caused by SW tranceivers). If the filter is not used, jumper module **RJP** must be installed in its position.

2.4.2. Diplex filters

The GAMMA optical node uses plug-in diplex filter modules **DF xxA** to provide separation between forward and reverse path frequency bands. **DF xxA** modules are installed at the node input and outputs. This plug-in solution allows flexibility in the reverse path configuration – free choice of reverse path frequency range.

If the reverse path is not used, jumper modules **AT 800** must be installed in place of **DF xxA** modules.

2.4.3. Reverse amplifier

The reverse path amplifier provides amplification of incoming reverse path signals from all output RF ports. The amplifier is available as a plug-in module of single amplifier **RAG 29-1** or dual amplifier **RAG 29-2**. The implemented architecture provides output level up to $116\text{dB}\mu\text{V}$ (DIN 45004 B) as well as very high gain up to 29dB (guaranteed amplifier module's gain).

Port to port gain depends on installed reverse configuration module **RCG xx** and amounts to:

- 25dB for optical receiver GAMMA O8X-11A-AE8 (RCG 04, RAG 29-1 and RCA modules installed).
- 22dB for optical receiver GAMMA O8X-22A-AE8 (RCG 03, RAG 29-1 and RCA modules installed).
- 20dB for optical receiver GAMMA O8X-33A-AF8 (RCG 01, RAG 29-1 and RCA modules installed).
- 26dB for optical node GAMMA O8X-11A-AE8 (RCG 04, RAG 29-1 and ORT modules installed).
- 23dB for optical node GAMMA O8X-22A-AE8 (RCG 03, RAG 29-1 and ORT modules installed).
- 21dB for optical node GAMMA O8X-33A-AF8 (RCG 01, RAG 29-1 and ORT modules installed).

If reverse signal amplification is not necessary, a reverse jumper **RJP** can be installed instead of reverse amplifier module.

2.4.4. Signal adjustment in reverse path

An attenuator at the each input of the reverse path (output in forward direction) is provided in **REV PAD x** sockets (where x is 2,3 or 4). In case RCA module is used (optical receiver) both: an attenuator and an equalizer are available at the output of the reverse path. The attenuation is adjusted using **ATG 8xx** modules in **REV PAD 5** socket, while the slope adjustments using **REQ xx** module in **REQ** socket and **ATG 8xx** module in **REV EQ PAD** socket. **REQ xx** module should be chosen depending on maximum frequency in reverse path while by changing **ATG 8xx** modules in **REV EQ PAD** socket required equalization can be obtained. If no tilt is needed **ATG 800** in **REV EQ PAD** socket should be installed.

If optical transmitter module **ORT** is installed there is no possibility to equalize characteristic. Level can be changed using the attenuator **ATG 8xx** placed directly on the transmitter module.

Reverse path ingress switch module **ISG 65** is a special diagnostic tool available for solving ingress problems in reverse direction. The module is installed in *ISG x* (where x is 2,3 or 4). It is a selectable three-state attenuator (0dB, 6dB and OFF), which can be managed remotely. It allows to locate a noise source area quickly and remotely in the access network and immediate troubleshooting. In a situation when cable operator does not use Network Management System NMS and ingress switches, there is no need to use any additional jumpers in *ISG x* sockets – autolink circuit provides connectivity automatically.

2.4.5. Test points

There are two or three (depending on version of the distribution amplifier) directional –20dB test points (one for each input) located at the input of the reverse path directly after the attenuators. Easy accessible F-connector enables quick and convenient measurements.

2.5. Powering

Powering of the GAMMA optical node is possible through any of the RF ports. In addition, the local powering port is also available to power the unit (Power Inserter). Quasi-square wave and a sine wave input voltage in a wide range of 35 ÷ 65 VAC is accepted.

A main SMPS fuse protects the power supply. It must be installed to enable optical nodes's powering. The optical node can be configured to pass AC current (up to 12A) through RF ports to distribution amplifiers in downward direction. It is also possible to pass the AC current (up to 15 A) through additional AC port (Power Inserter) - GAMMA can work as a power inserter if power supply is mounted in the same cabinet. The RF port and fuse-jumpers determine the powering scheme. Fuses can be installed in place of jumpers if current protection is required. By default jumpers are installed. Surge arrestors are placed at all RF ports, providing over-voltage protection and highly increasing optical node's reliability.

Advanced technological solutions are applied in SMPS architecture, providing high grade of efficiency and very low power consumption while accepting a very wide range of input voltages. The recommended voltage range is 35 ÷ 65 VAC. Low power consumption combined with extensive voltage range reduces number and cost of the entire CATV system's remote power-supply devices.

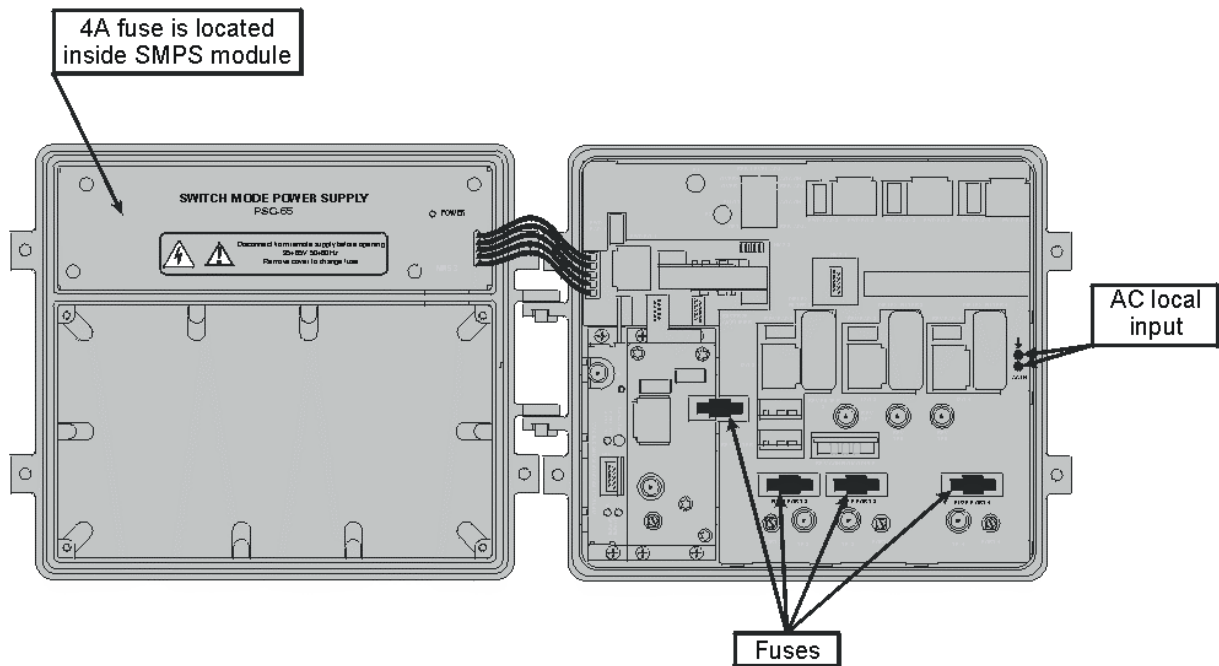

Fig. 4. Fuses location.

2.6. NMS monitoring system

GAMMA optical node has been prepared for status monitoring. It can be equipped with the interface connected to NMS modem. The interface and the modem are placed in the cover and are connected with the SMPS, optical receivers and transmitters and the ingress switch modules while allowing monitoring and controlling of fundamental node parameters.

2.7. Inside overview

The location of all elements and plug-in modules in GAMMA optical node for the forward path is shown in Fig. 5 and for the reverse path in Fig. 6.

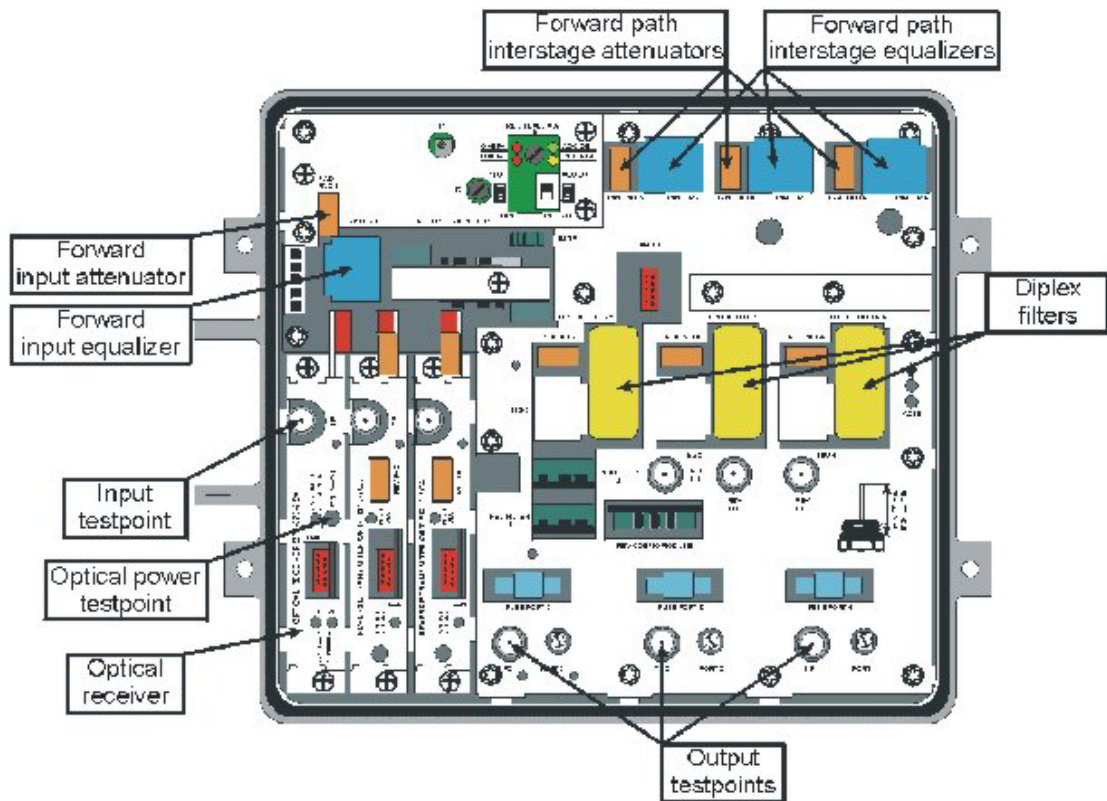

Fig. 5. Location of elements and plug-in modules in forward path.

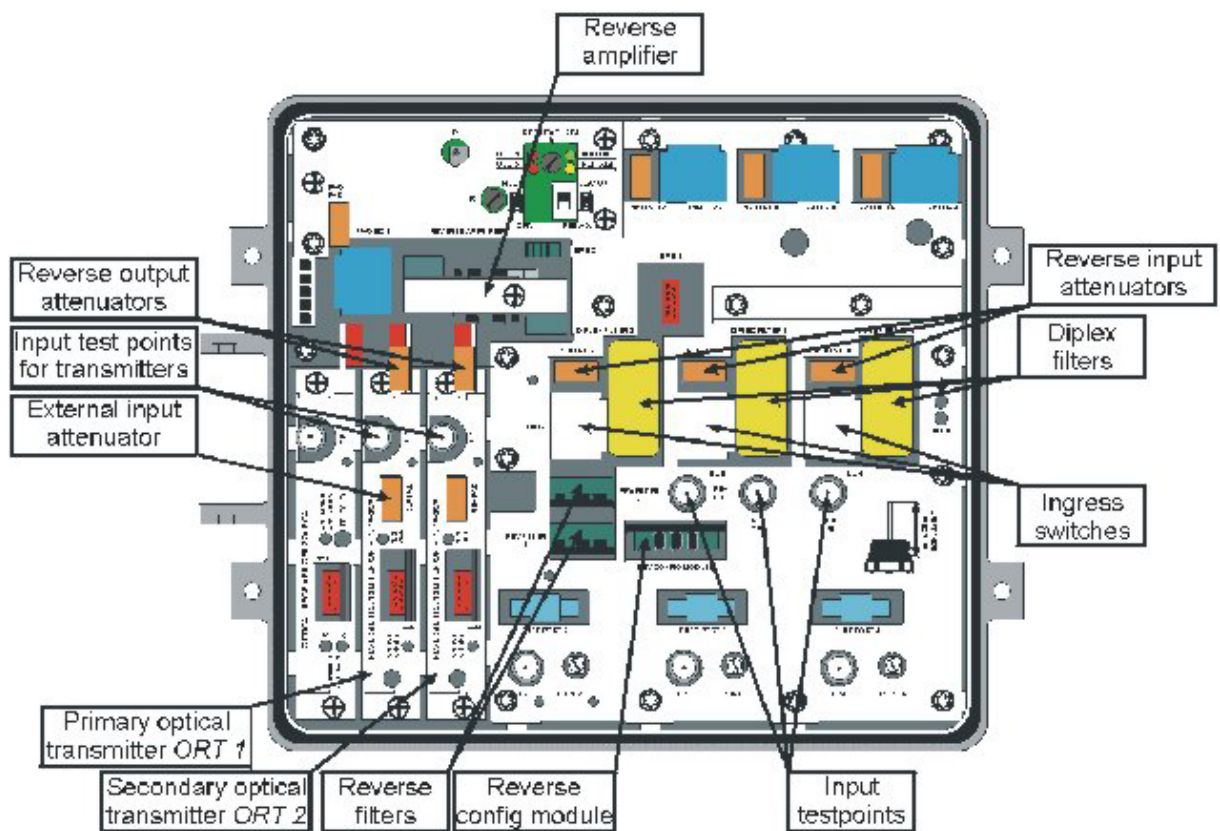

Fig. 6. Location of elements and plug-in modules in reverse path.

2.8. Housing

The housing provides both environmental protection and heat dissipation for the optical node. Durable, weatherproof, die-cast aluminium housing with large radiator allows operation in a wide ambient temperature range ($-40 \div +60^{\circ}\text{C}$). Very high protection class IP 67 enables installation and operation even in very bad environmental conditions. A silicone rubber gasket provides a hermetic seal, while a metal gasket provides electromagnetic compatibility.

The compact housing of GAMMA optical node requires only little mounting space and allows installation in both typical building and street cabinets. An overview of the housing (front and side) is presented in Fig. 7. Three universal mounting brackets enable easy installation of the die-cast housing.

GAMMA optical node is equipped with four RF ports and one fiber port on the bottom side of the housing and one additional AC port on the right side. The node is equipped with an easily removable cover, which is fastened using four M5 socket-head screws.

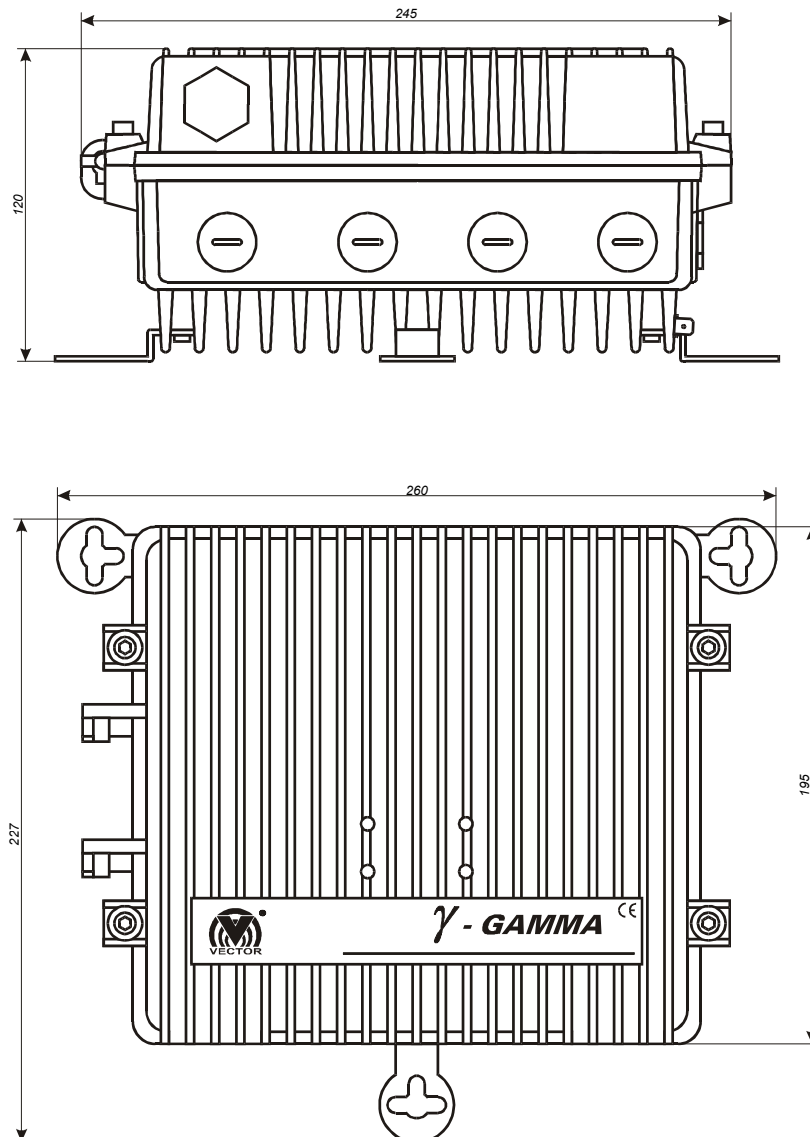

Fig. 7. An overview of GAMMA optical node's housing.

3. MOUNTING

3.1. Preparing for node installation

Inspect the outside of the unit to check the convection fins, cable entry ports and cover bolts for damage. Ensure that each unit has its mounting hardware package, containing three universal mounting brackets.

3.2. Installation

Before mounting the optical node, fix the included universal mounting-brackets to the backside of the housing using the provided screws. Then screw down to a wall or mounting-board the universal brackets at the backside of the housing, using three screws max. \varnothing 6mm. Only proper mounting of the node guarantees good thermal conditions.

ATTENTION!

Due to thermal conditions it is always necessary to mount the optical node vertically, with the cable connectors pointing downward. Otherwise heat dissipation for the optical node is not working correctly.

Properly mounted optical node has the temperature of about 35°C (ambient temperature 20°C, free airflow). If the unit lays its temperature can rise up to 50°C because the heatsink does not work properly.

3.3. Grounding

To guarantee node operational safety the die-cast housing must be grounded. Use a 4mm² copper wire that is tightly connected to the connector on the right side of the housing.

3.4. Cable connection

Turn off all power sources feeding into the unit before installing the cable and connectors. If one of the output ports is not used, it should be terminated with 75 Ω terminator (**ATG 075** module) and the fuse associated with this port should be removed. Use PG11 connectors to connect coax cables with the connectors at the RF ports. If the optical node is installed in open air, it is recommended to use heat-shrink hose to cover the cable entry ports and the entire assembled connectors. Be sure that the hose is long enough – it should be at least 5cm beyond the cable jacket edge.

In order to connect fiber connectors one should comply with the following procedure (see Fig. 7):

1. Unscrew PG-16 connector,
2. Remove the rubber gasket,
3. Put the fibers into the holes in the gasket,
4. Install the gasket and tight up the PG-16 connector.

Optical connectors are labeled as follows:

- *FWD A* – primary optical receiver,
- *FWD B* – secondary (redundant) optical receiver,
- *REV 1* – primary optical transmitter,
- *REV 2* – secondary optical transmitter.

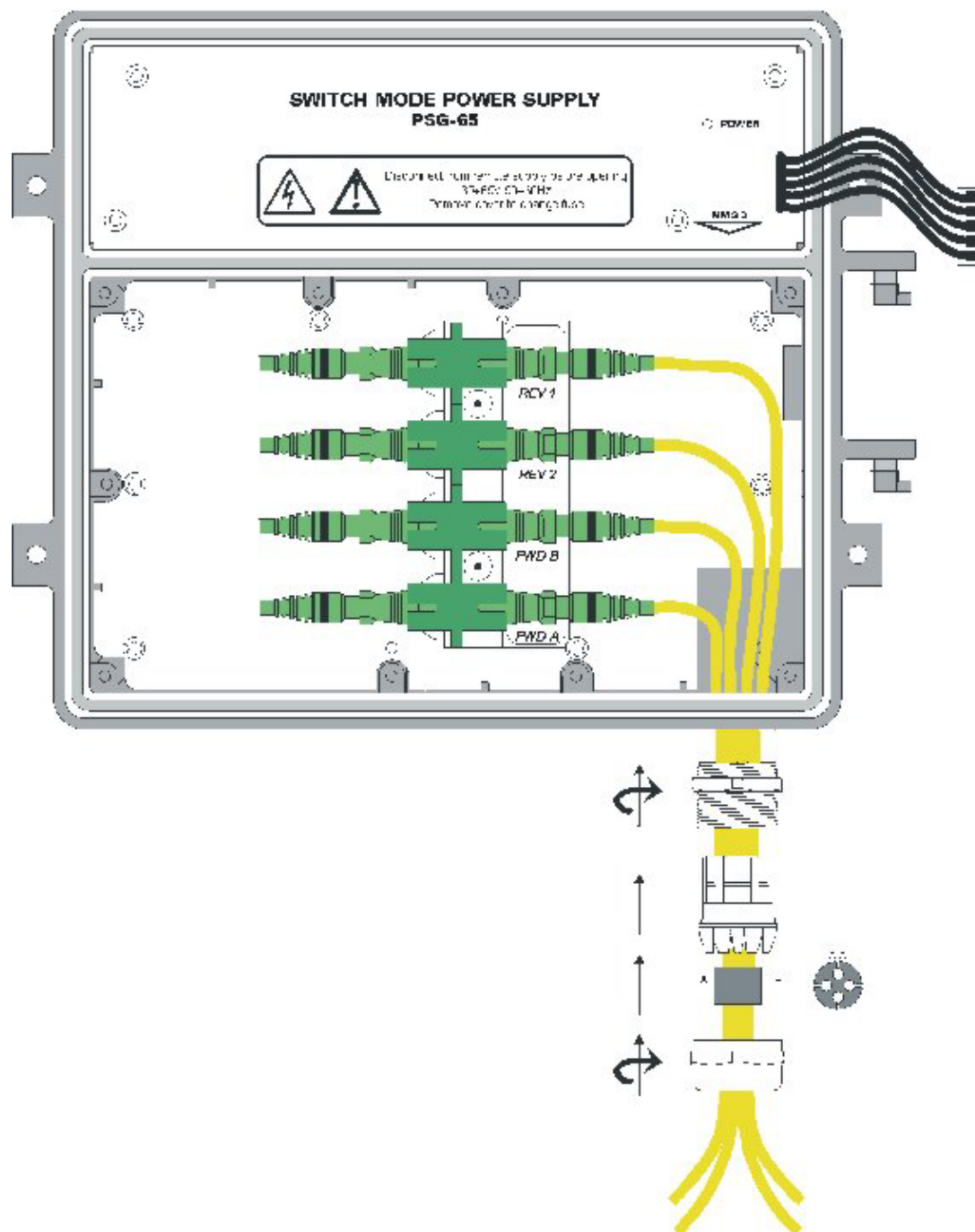

Fig. 8. Fiber connectors installation.

4. CONFIGURATION AND SETUP

4.1. Fusing

Check the powering scheme in the system map for power-through fusing or power stop (see point 2.5.). The powering can be supplied locally through additional AC input or remotely from the RF output ports (see Fig. 1, Fig. 2 or Fig. 3). In this case, adequate fuse-jumper must be installed. Check power-through fuse-jumpers (RF ports and AC port) for installation as specified in the system map and presence of SMPS fuse. Install the right fuse if current protection is required. Please refer to Fig. 4.

4A “slow-blow” fuse should be used in SMPS. In order to replace the fuse in the SMPS module **PSG xx** it must be removed. To remove this module please comply with the following procedure (see Fig. 9):

1. Lever the SMPS module using screwdriver,
2. Replace the fuse using the fuse of the same type,
3. Put the module into the slot in the cover and pressure it until refusal is being felt.

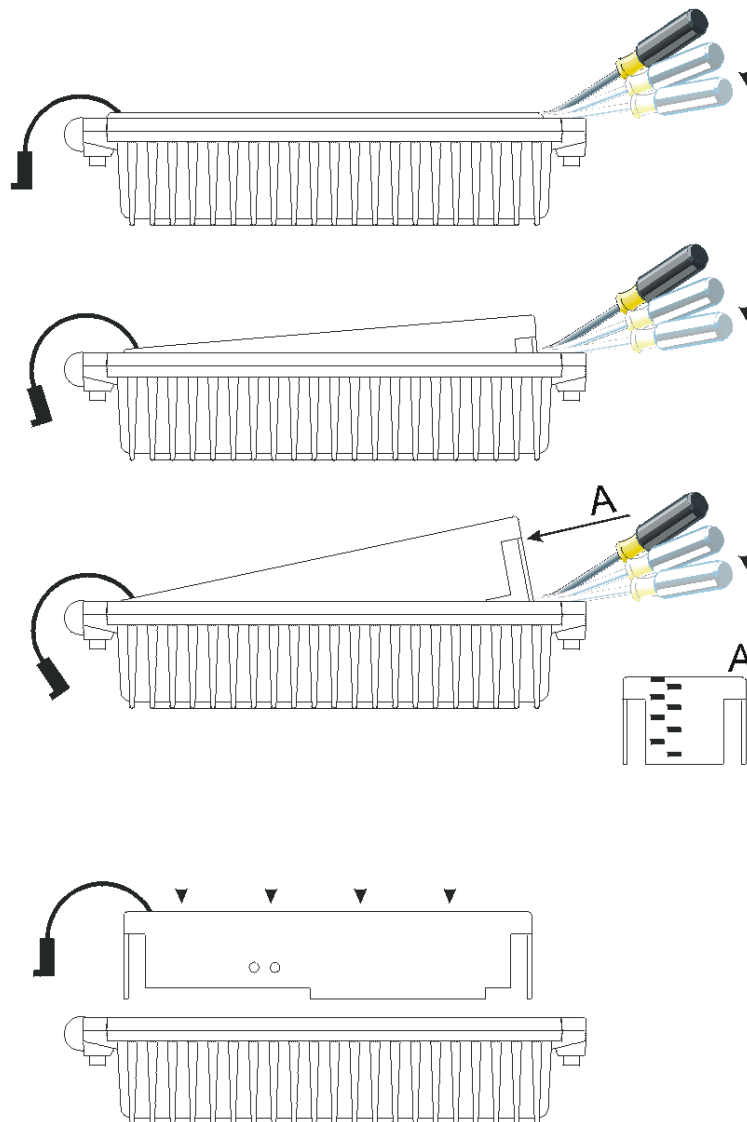

Fig. 9. SMPS module dismounting.

ATTENTION!

Improper fuse installation can:

- damage node,
- fail to power the node,
- fail to distribute remote power.

Always use the same fuse type while replacing!

4.2. Configuration of the optical node

4.2.1. Forward path plug-in modules

Check installed plug-in modules in the forward path before activating the optical node. The right forward path configuration must contain following plug-in modules (see Fig. 1, Fig. 2, Fig. 3 and Fig. 5):

- optical receiver **OFR 870-xxx** or **OSR 870-xxx** in *OFR* socket,
- input attenuator **ATG 8xx** in *FWD PAD 1* socket ,
- input equalizer **EQ 8xx** or cable simulator **CS 8xx** or **AT 800** jumper in *FWD EQ 1* socket,
- interstage equalizers **EQ 8xx** or **AT 800** jumpers in *FWD EQ x* socket (x = 2,3 or 4) and interstage attenuators **ATG 8xx** in *FWD PAD x* socket (x is 2,3 or 4),
- output diplex filters **DF xxA** or **AT 800** jumpers in *DIPLEX FILTER x* socket,
- **AGC/ASC** module in *AGC* socket. If AGC/ASC feature is not necessary instead of this module high-pass filter module **HPG xx** should be installed (factory mounted).

ATTENTION!

Always use jumpers AT 800 in place of unused module-positions for diplex filters and equalizers.

The optical node does not work properly if any of the modules' position in forward path is empty.

4.2.2. Reverse path plug-in modules

Check installed plug-in modules in the reverse path before activating the optical node. The right reverse path configuration must contain following plug-in modules (see Fig. 1, Fig. 2, Fig. 3 and Fig. 6):

- optical transmitter **ORT** in *ORT 1* socket (or RCA module if GAMMA works as optical receiver),
- fixed attenuators **ATG 8xx** in *ORT REV PAD* socket,
- reverse path amplifier module **RAG 29-1** in *REVERSE AMPLIFIER* socket. If the amplification for reverse path is not necessary the **RAG 29-1** module should be replaced with jumper **RJP**.
- optionally ingress switch **ISG 65** module in *ISG x* socket (x = 2, 3 or 4),
- fixed attenuator **ATG 8xx** in *REV PAD x* socket (x = 2, 3 or 4),
- reverse configuration module **RCG xx** in *REV CONFIG MODULE* socket,
- reverse filter module **RHP 15** in *REVERSE FILTER 1* socket. If the filtering is not required the **RHP 15** module should be replaced with jumper **RJP**.

ATTENTION!

The node does not work properly if any of the modules' position in reverse path is empty. The only exception to the rule is ISGx (x = 2, 3 or 4) socket for ingress switch module ISG 65 where autolink circuit provides connectivity automatically.

4.3. Set-up and adjustment

All set-up and adjustment procedures are to be carried out with opened cover. Close cover after finishing this process.

4.3.1. Forward path

The set-up and adjustment of the forward path for optical node GAMMA must comply with the following procedure:

1. Check interstage position for presence of plug-in equalizers in *EQ PAD x* sockets ($x = 2, 3$ or 4) and interstage attenuators in *FWD PAD x* sockets ($x = 2, 3$ or 4). Although there is no strict requirement, it is strongly recommended to work with interstage adjustments. More about interstage adjustments one can find in chapter 2.3.5.
2. Measure the RF input signal using test point at optical receiver OFR 870-xxx (OSR 870-xxx).
3. Input optical power can be measured using test point placed at the optical receiver module. The test point provides DC voltage scaled by 1V/mW. In addition the LED indicators (one for primary receiver and one for redundant, if it is installed) are provided. If LED lights red the optical input power is less than -5dBm, otherwise it lights green. Another LED shows which receiver is active (it lights yellow if redundant receiver is active, otherwise the LED does not light at all).
4. Plug in input attenuator in *FWD PAD 1* socket and input equalizer in *FWD EQ 1* socket. Regard the values provided by network design.
5. Connect CATV meter to the output test point and check if output signal has reached the designed level and slope.
6. The adjustment of level and slope of the signal should be performed by exchange of interstage attenuator and equalizer modules in *FWD PAD x* and *FWD EQ x* sockets ($x = 2, 3$ or 4).

If the optional automatic gain control module AGC is required one should perform its alignment as described in section 4.3.1.1.

4.3.1.1. Automatic gain control AGC

If the optical node is not equipped with the automatic gain control module **AGC xxx-x** or **AGC 000-x**, in order to install it one should comply with the following procedure (see Fig. 10):

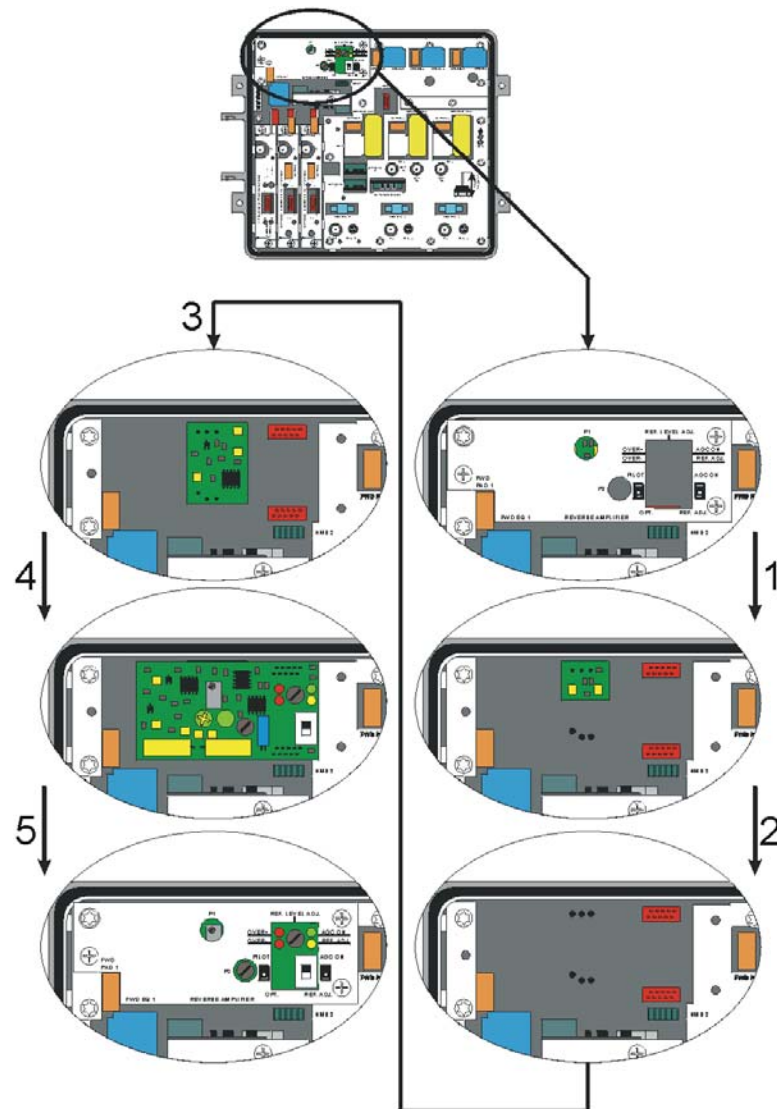

Fig. 10. AGC module mounting.

1. Unscrew the AGC masking frame,
2. Remove installed **HPG xx** module,
3. Plug AGC attenuator into the socket, from which **HPG xx** module has been removed,
4. Plug **AGC xxx-x** or **AGC 000-x** module into the socket,
5. Mount masking frame.

In order to adjust the automatic gain control circuit one should comply the following procedure:

1. Plug-in input attenuator module **ATG 8xx** in *FWD PAD 1* socket and input equalizer module **EQ 8xx** in *FWD EQ 1* socket. Regard the values provided by network design
2. Set on the switch at **AGC** module in position REF ADJ – yellow LED on module should be turned on.
3. Align REF LEVEL ADJ potentiometer until red LED described OVER+ turn on. This will set minimal attenuation of **AGC** module
4. Increase interstage attenuator by 4dB (in comparison to provided in the network design).
5. Align input attenuation to get desired output level.
6. Set back the interstage attenuator to the value provided by the network design.
7. Align REF LEVEL ADJ potentiometer to get desired output level.
8. Set on the switch at **AGC** module in position AGC ON – green LED on

module should be turned on.

9. Align potentiometer *P2* to get desired output level.

Note that the procedure described above is given for symmetrical $\pm 4\text{dB}$ regulation dynamics window. If the window should not be symmetrical increase the interstage attenuation by value different from 4dB. For example by 0dB to get $+8 \div 0\text{dB}$ window or by 8dB to get $+0 \div -8\text{dB}$ window.

4.3.2. Reverse path

There are two ways of transmitting signals in the reverse path: using coaxial cables or using fibers. Both options are possible to implement in optical node GAMMA depending on the needs and requirements of cable operator.

In the case of coaxial output of the in optical node reverse path the RCA module has to be installed. RCA module is connected with the main board via connection board. One should pay the attention to correctly connect that connection board. In order to install output module for coaxial reverse output RCA one should comply with the procedure illustrated in Fig. 11:

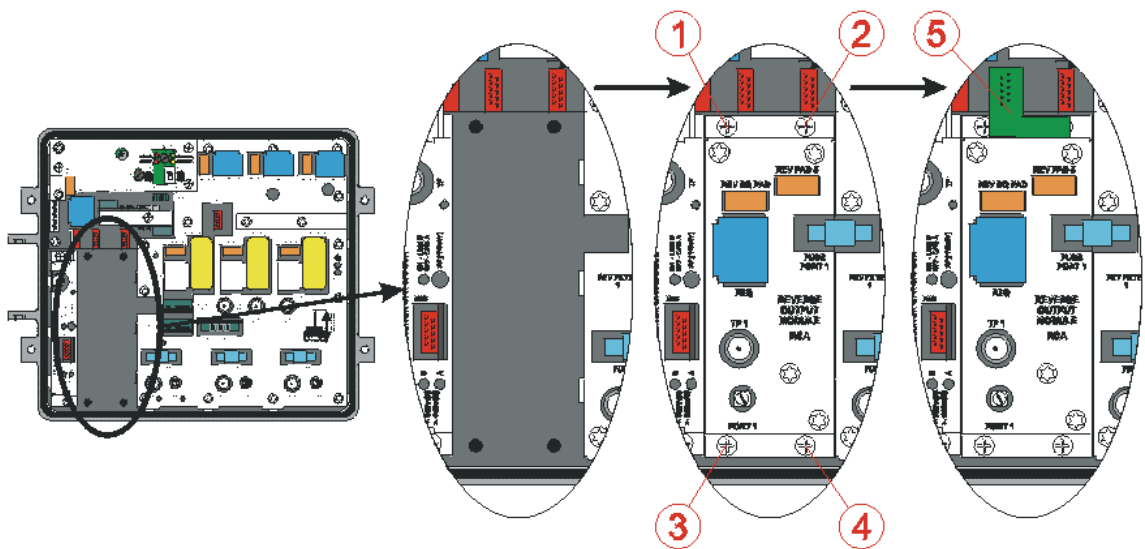
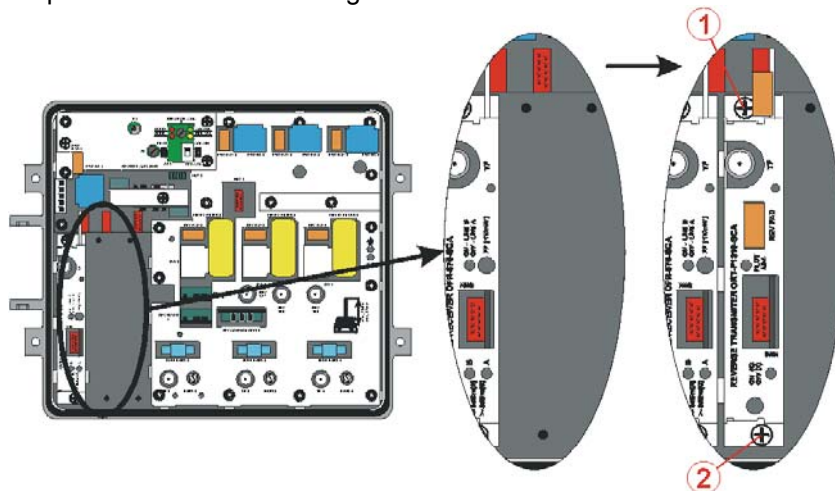
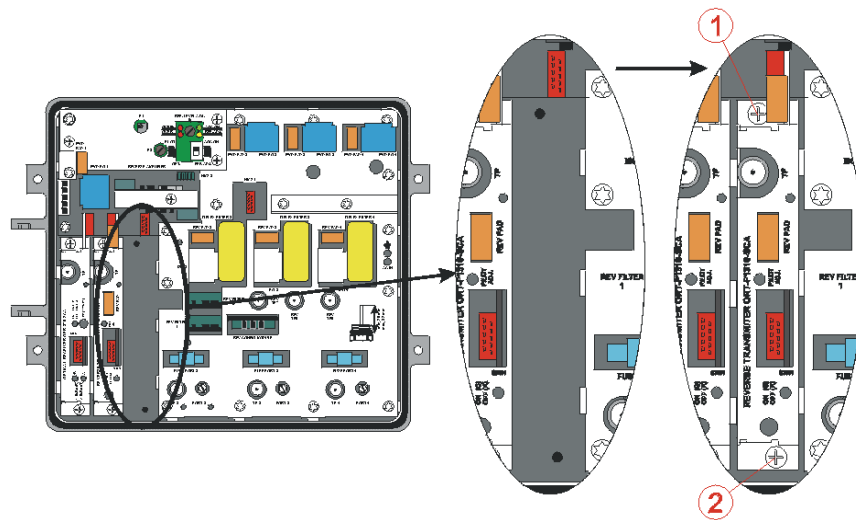

Fig. 11. RCA module installation.

In the case of optical output for reverse path in optical node the optical reverse transmitter module **ORT** has to be installed. If dual reverse path is required two optical reverse transmitters have to be installed. One should pay attention to proper installation of fibers, which have to be mounted using fiber holders 1-7. In order to install optical reverse transmitter module **ORT** one should comply with the following procedure illustrated in Fig. 12:



Assembling of the *ORT 1* transmitter



Assembling of the ORT 2 transmitter

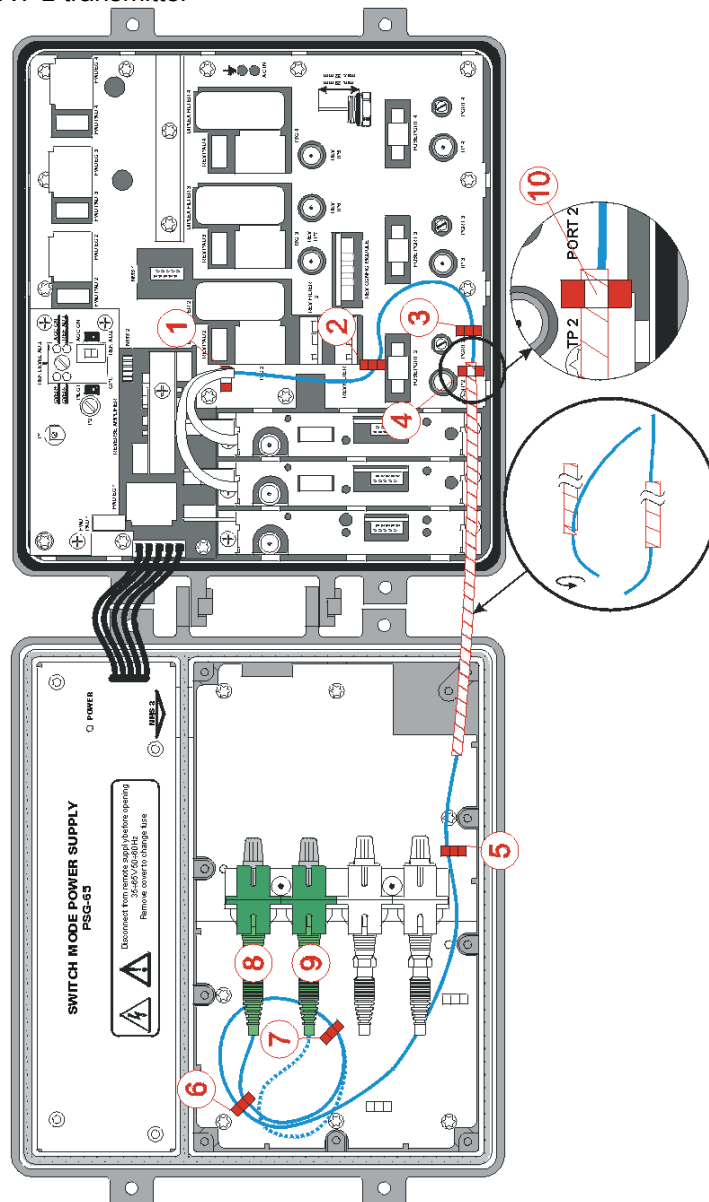

Fig. 12. ORT module mounting.

4.3.2.1. Reverse path set-up and adjustment

The set-up and adjustment of the reverse path for distribution amplifier GAMMA must comply with the following procedure:

1. If reverse path is used, input and output diplex filters **DF xxA** must be installed in *DIPLEX FILTER x* socket ($x = 1, 2, 3$ or 4). Input and output diplex filters must be installed to let the reverse path work properly.
2. Install reverse path module **RAG 29-1** or jumper **RJP** for the passive reverse path. Reverse amplifier should be placed in *REVERSE AMPLIFIER* socket and tightened using M3 screw, which is shipped with module (see Fig. 12).
3. Check if all modules in signal path are installed (only the ingress switch modules **ISG 65** can be omitted).
4. Adjust reverse output RF signal level by changing attenuator **ATG 8xx** in the socket at the optical reverse transmitter module **ORT**. Input attenuators **ATG 8xx** located in *REV PAD x* sockets ($x = 2, 3$ or 4) allows fine level adjustments of input reverse signals from all RF ports. Reverse path test points can be used to measure level of incoming reverse signals.

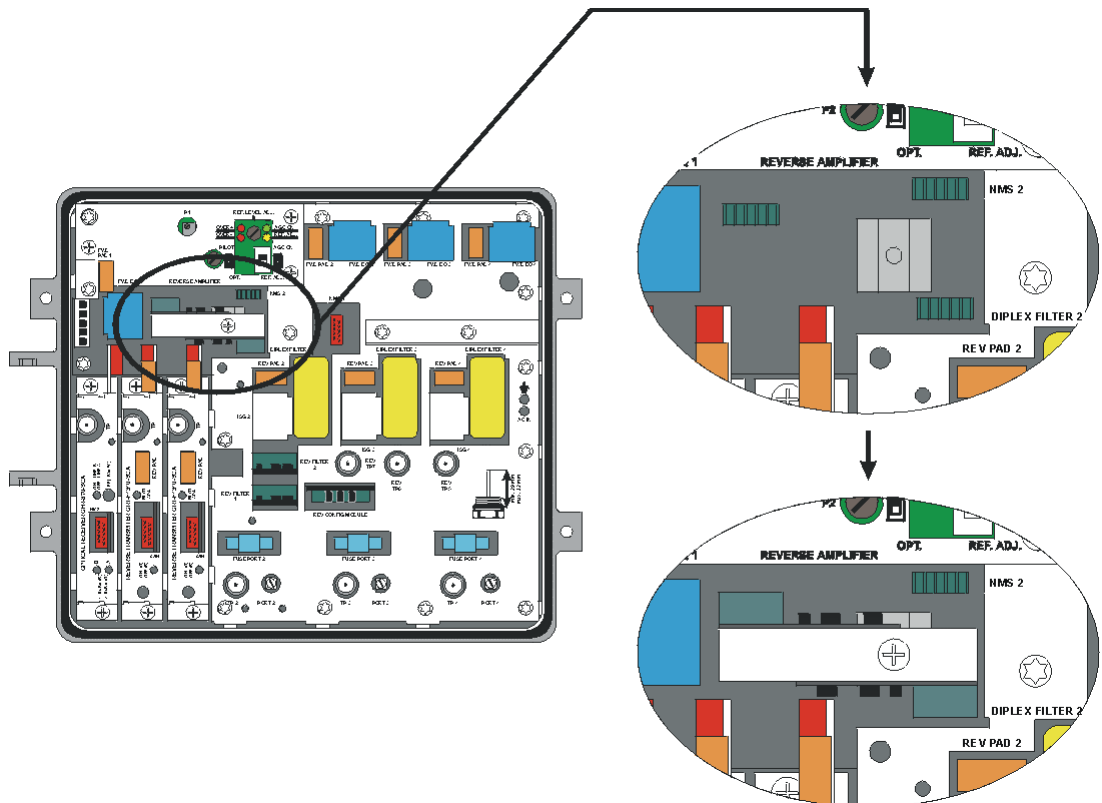

Fig. 13. RAG 29-x module mounting.

Typically there is only one optical reverse output (one optical reverse transmitter). In such configuration there are used: reverse amplifier module **RAG 29-1** and reverse configuration module **RCG 01** or **RCG 03**. The only reverse output from the optical node is the output of optical reverse transmitter module **ORT**.

However, dual reverse path configuration is available for optical node GAMMA. In this case dual reverse amplifier module **RAG 29-2** and two optical reverse transmitter modules **ORT** are required as well as one of the reverse configuration modules **RCG 02**, **RCG 04**, **RCG 05**, **RCG 06** or **RCG 07**. The reverse configuration modules allow flexible matching of the reverse path to the requirements of the cable operator (redundancy or segmentation). If dual reverse path is used the **RHP xx** or **RJP** modules have to be placed in *REV FILTER 1* and *REV FILTER 2* sockets (for single reverse path only *REV FILTER 1* socket must be configured). If amplification in reverse path is not required **RAG 29-1** module

should be replaced by **RJP** module and **RAG 29-2** module should be replaced with two **RJP** modules.

Attention should be paid in order to ensure proper RF reverse signal level driving the laser. The level should be kept in a window, in which best noise to power ratio NPR performance can be reached. If the level is too low, noise floor is too high to obtain required NPR value. However increasing input RF level may cause increasing intermodulation distortions and laser clipping. More information with NPR diagrams vs. laser RF driving levels for both FP and DFB lasers is covered in chapter 7 describing optical reverse transmitters modules. Proper input level is necessary to obtain right OMI value. Regard the values provided by network design.

4.4. Cover closing

After connecting coax cables and finishing optical node configuration, close the housing cover and tighten the cover bolts (M5 head-socket screws) following the sequence: screw 1, 2, 3, 4 or 3, 4, 1, 2 (see Fig. 14).

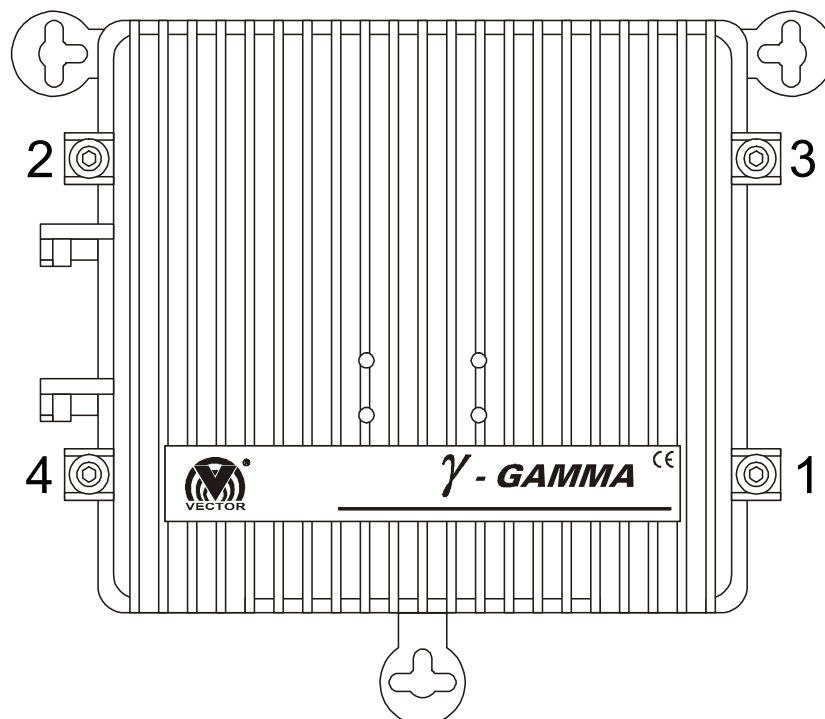

Fig. 14. Node-cover closing and tightening diagram.

5. UPGRADING GAMMA OPTICAL NODE

Modular and scalable construction allows the user to fit the Gamma optical node to individual and specific requirements of cable operator. This feature gives the cable operator the possibility of step-by-step development of the network and further fiber penetration in order to meet the increasing demand of transmission capacity determined by growth of services' penetration. Optical node GAMMA can be equipped with two optical reverse transmitters allowing segmentation or redundancy option for reverse path as well as two optical receivers allowing redundancy for forward path. The possibility of providing full redundancy in both directions is of great importance in case of provisioning bi-directional telecommunication services requiring reliable transmission platform (e.g. telephony).

Optical connectors and pigtails are labeled as follows:

- *FWD A* – primary optical receiver,
- *FWD B* – secondary (redundant) optical receiver,
- *REV 1* – primary optical transmitter,
- *REV 2* – secondary optical transmitter.

ATTENTION!

Ensure that the label on the pigtail is the same as that on the connector.
Be careful when handling with fibers. Mechanical defects can affect the transmission.

5.1.1. Redundant optical receiver

In optical node GAMMA it is possible to install optical receiver with redundancy module **OSR 870-xxx**. This optical receiver with redundancy is installed as a plug-in module instead the optical receiver module **OFR 870-xxx**. In order to install the optical receiver with redundancy module one should comply with the following procedure (see Fig. 15):

1. Remove the **OFR 870-xxx** module from the optical node, if it is installed,
2. Put the **OSR 870-xxx** module inside the optical node and tighten it using screws,
3. Connect the pigtails to distribution frame being placed in upper cover of the housing.

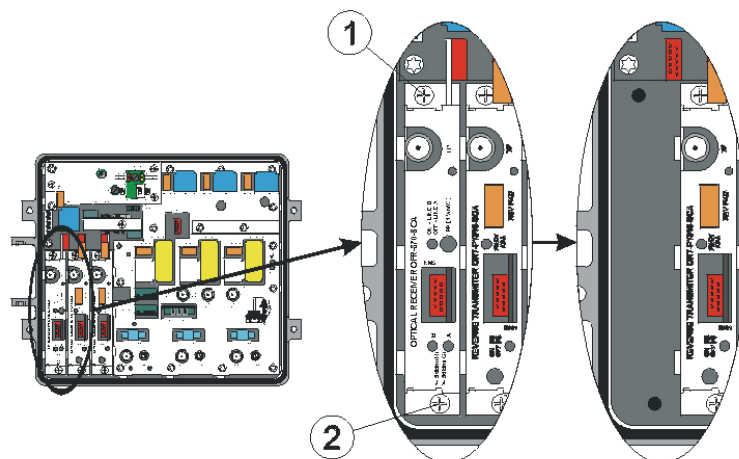

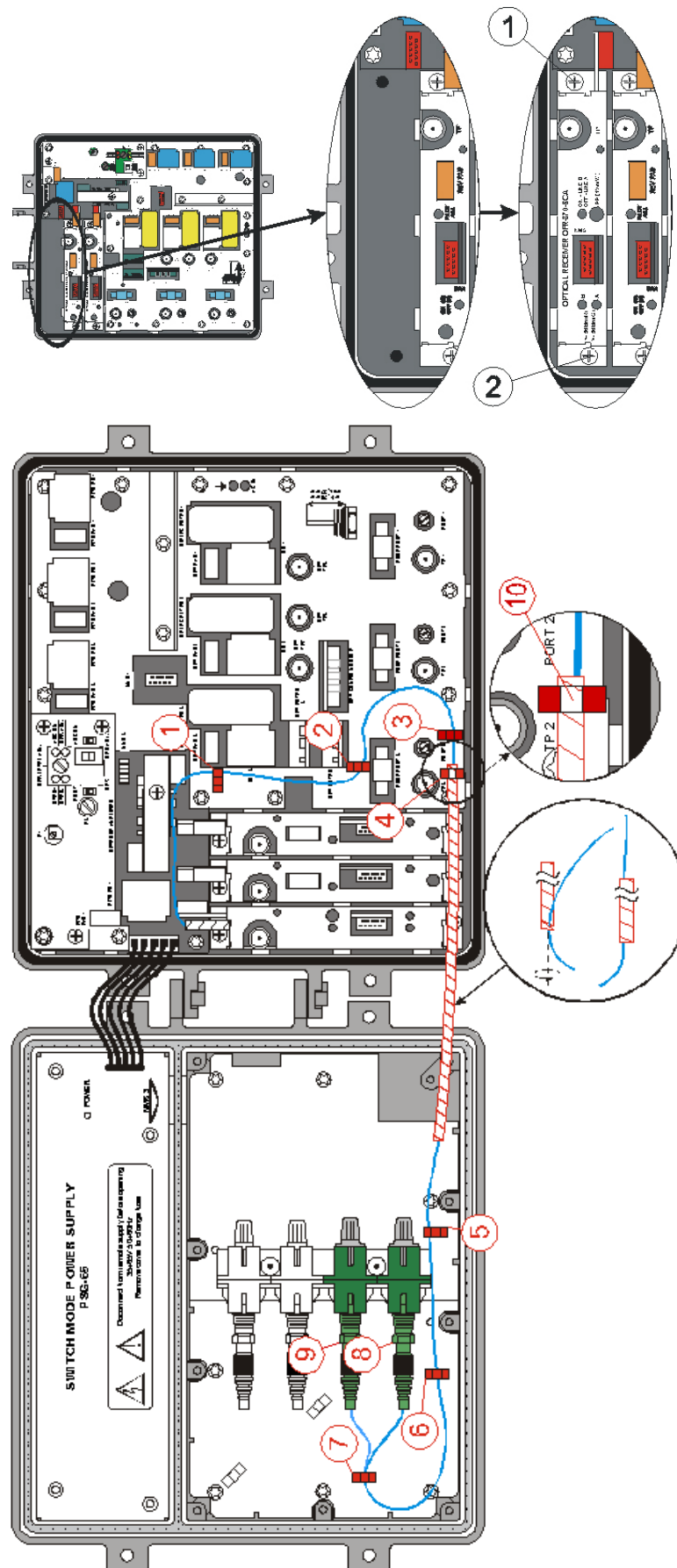

Fig. 15. Optical receiver with redundancy module OSR installation.

5.1.2. Additional gain in reverse path

If for a particular implementation of optical node GAMMA available 20dB of gain in reverse path (depending on reverse path configuration module **RCG xx**) is not enough for user's requirements, there is an option to increase the effective gain by additional 20dB by installing additional active band-pass filter module **OLPA xx** (so one can obtain about 40dB depending on reverse configuration module installed). To install the **OLPA xx** module one should comply with the following procedure (see Fig. 16):

1. Remove the **ORT x** module from the optical node, if it is installed,
2. Disassemble the housing of the **ORT** module,
3. Remove **OLP xx** module, which is placed inside transmitter housing
4. Plug **OLPA xx** module in place of removed **OLP xx** module,
5. Assemble the housing of the **ORT** module,
6. Put the **ORT** module inside the optical node and tighten it using screws.

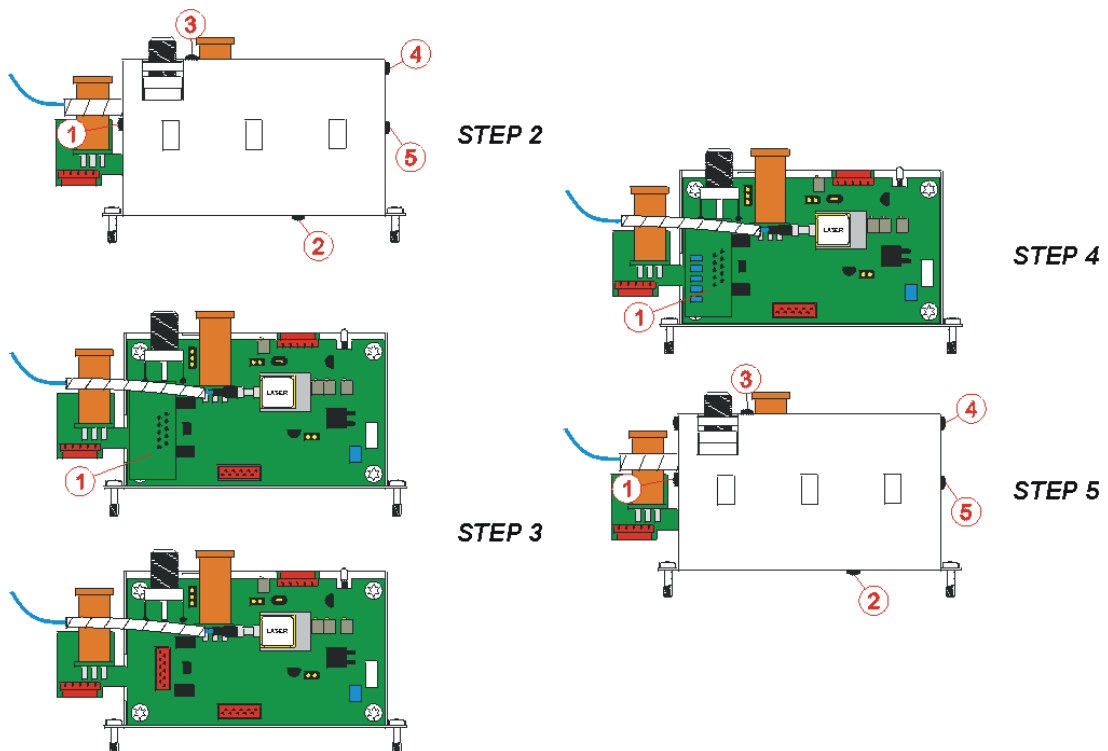

Fig. 16. OLPA xx module installation.

5.1.3. Optional single tone reference generator module

In optical node GAMMA there is an option to install single tone reference generator module **RRG xxx** inside the optical reverse transmitter **ORT** module. In order to install the **RRG xxx** module one should comply the following procedure (see Fig. 17):

1. Remove the **ORT** module from the optical node, if it is installed,
2. Disassemble the housing of the **ORT** module,
3. Install the **RRG xxx** module inside the optical transmitter housing,
4. Assemble the housing of the **ORT** module,
5. Put the **ORT** module inside the optical node and tighten it using screws,
6. Adjust pilot level using potentiometer on the top side of the optical transmitter described *PILOT ADJ.*

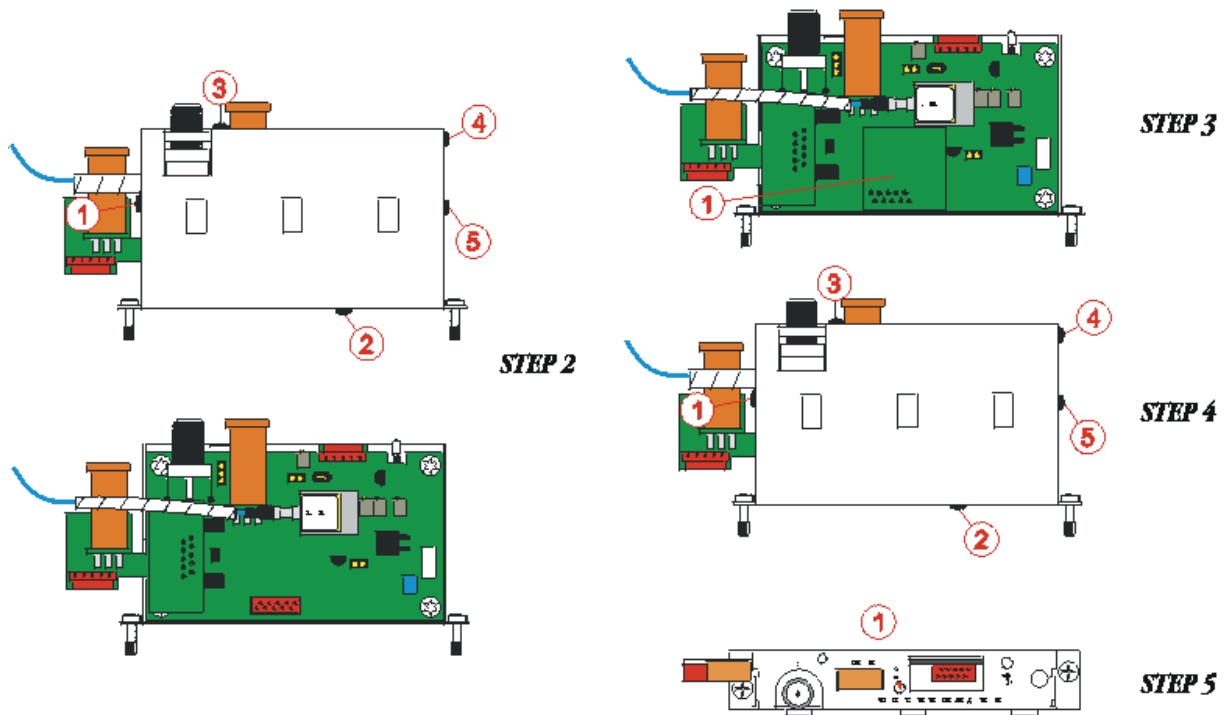

Fig. 17. RRG xxx module installation.

5.1.4. External RF input 5 ÷ 210MHz for reverse path

If more bandwidth is required for reverse transmission an additional external RF 5 ÷ 210MHz input is provided at **ORT** module. This input is available only for optical transmitter module placed in socket **REV 1**. In order to activate this external RF 5 ÷ 210MHz input option one should comply with the following procedure (see Fig. 18):

1. Remove the hole plug,
2. Install the PG-11 port. The pin should have the length of 21 ÷ 25mm..
3. Tighten up the pin using screwdriver.
4. Remove the terminator **ATG 075** from transmitter module from **REV PAD** position and plug in attenuator **ATG 8xx**.

ATTENTION!

The pin must not be longer than 25mm, otherwise the transmitter can be damaged.

When external RF 5 ÷ 210MHz input is not used, the **ATG 075** module should be plugged in the **REV PAD** socket at the transmitter module.

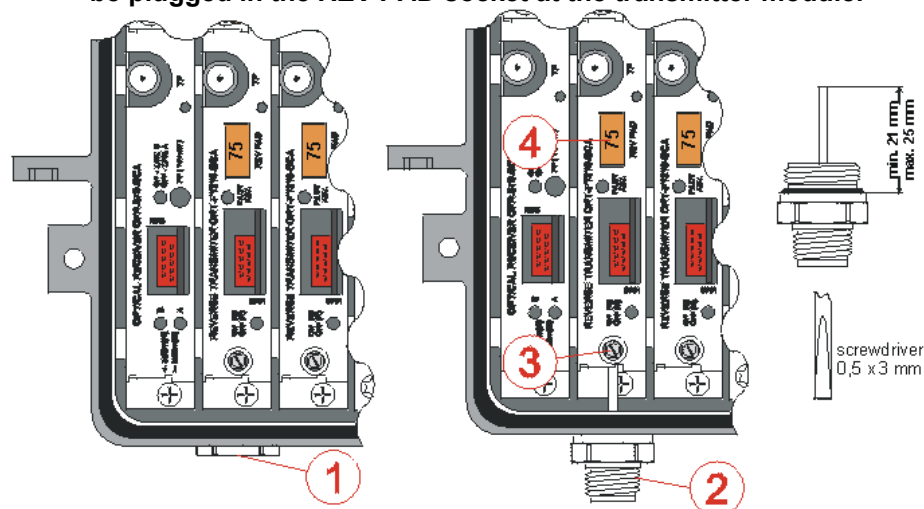

Fig. 18. External reverse RF 5 ÷ 210MHz input activation

6. GAMMA OPTICAL NODE TECHNICAL SPECIFICATION

6.1. GAMMA O8X-33A-AF8

PARAMETER	VALUE	COMMENT
Wavelength [nm]	1100 ÷ 1600	
Optical input power range [dBm]	-5 ÷ +2	
Equivalent Input noise [$\text{pA}/\sqrt{\text{Hz}}$]	≤ 8	
Optical connector	SC/APC	Others on request
Optical power test point [V/mW]	1 ± 0.1	
RF level at the output of the OFR receiver [dB μ V]	78 ± 1	4.5% OMI/channel, 0dBm input optical power
Optical Power Indicator [dBm]	- 5	Green – optical power > -5dBm Red – optical power < -5dBm
Forward bandwidth [MHz]	47...85 ÷ 862	DF duplex filters
Maximum output RF level [dB μ V]	$3 \times 117 \pm 1$	0dBm input optical power, 4.5% OMI/channel
Flatness [dB]	± 0.75	DF duplex filters, AT 800 and ATG 800 jumpers
Slope [dB]	± 1	DF duplex filters, AT 800 and ATG 800 jumpers
CNR [dBc]	56	0dBm input optical power, 4.5%OMI/ channel, 10dB passive optical loss
Output level typ. [dB μ V] CTB \leq -60dBc CSO \leq -60dBc	110 110	According to EN 50083-3; 9dB interstage equalizer, 42 CENELEC carriers, optical transmitter distortions not included
Reverse bandwidth [MHz]	5 ÷ 30...65	DF duplex filters
Reverse gain [dB]	21 ± 0.75	Ports 2,3,4 to ORT reverse transmitter; DF duplex filters, ATG 800 jumpers, RCG 01 configuration module, RAG amplifier
Reverse noise figure [dB]	≤ 12	DF duplex filters, ATG 800 jumpers, RCG 01 configuration module and RAG amplifier
NPR [dBc]	≤ -60	RAG amplifier, 27dB μ V/Hz signal @ 60MHz
HUM modulation @12A [dBc] 5÷15MHz 15÷65MHz 85÷862MHz	≤ -55 ≤ -60 ≤ -60	@791.25MHz
RF return loss [dB]	≤ -18	$f \leq 40\text{MHz}$; $f > 40\text{MHz}$: +1.5dB/oct
Test point @ input [dB]	-20 ± 1	Relative to the output of OFR receiver
Test points @ outputs [dB]	-20 ± 1	Directional coupler
Test points @ reverse inputs [dB]	-20 ± 1	Directional coupler
Number of RF ports/connectors type	4 / PG11	Port 1 – reverse auxiliary input 5 ÷ 210MHz for ORT transmitter
AC voltage range [V]	35 ÷ 65	AC 50÷60Hz
Maximum current for AC IN port [A]	15	Power insertion port
Maximum current for RF port [A]	12	All RF ports, except Port 1
AC current consumption [mA] 35VAC 48VAC 65VAC	1500 1150 850	RAG amplifier and OFR receiver
AC power consumption [W]	40 42	RAG amplifier and OFR receiver RAG amplifier, OFR receiver and ORT transmitter
Protection class IP	IP 67	
Operating ambient temperature range [°C]	-40 ÷ +60	
MTBF [years]	>30	@25°C, without ORT transmitter
Dimensions (W x L x H) [mm]	245 x 195 x 125	
Weight [kg]	4.3	

Specifications are subject to change without notice.

6.2. GAMMA O8X-22A-AE8

PARAMETER	VALUE	COMMENT
Wavelength [nm]	1100 ÷ 1600	
Optical input power range [dBm]	-5 ÷ +2	
Equivalent Input noise [pA/√Hz]	≤ 8	
Optical connector	SC/APC	Others on request
Optical power test point [V/mW]	1 ± 0.1	
RF level at the output of the OFR receiver [dBμV]	78 ± 1	4.5% OMI/channel, 0dBm input optical power
Optical Power Indicator [dBm]	- 5	Green – optical power > -5dBm Red – optical power < -5dBm
Forward bandwidth [MHz]	47...85 ÷ 862	DF diplex filters
Maximum output RF level [dBμV]	2 x 117 ± 1	0dBm input optical power, 4.5% OMI/channel
Flatness [dB]	± 0.75	DF diplex filters, AT 800 and ATG 800 jumpers
Slope [dB]	± 1	DF diplex filters, AT 800 and ATG 800 jumpers
CNR [dBc]	56	0dBm input optical power, 4.5% OMI/ channel, 10dB passive optical loss
Output level typ. [dBμV] CTB ≤ -60dBc CSO ≤ -60dBc	114 112	According to EN 50083-3; 9dB interstage equalizer, 42 CENELEC carriers, optical transmitter distortions not included
Reverse bandwidth [MHz]	5 ÷ 30...65	DF diplex filters
Reverse gain [dB]	23 ± 0.75	Ports 3,4 to ORT reverse transmitter; DF diplex filters, ATG 800 jumpers, RCG 03 configuration module, RAG amplifier
Reverse noise figure [dB]	≤ 10	DF diplex filters, ATG 800 jumpers, RCG 03 configuration module and RAG amplifier
NPR [dBc]	≤ -60	RAG amplifier, 27dBμV/Hz signal @ 60MHz
HUM modulation @12A [dBc] 5÷15MHz 15÷65MHz 85÷862MHz	≤ -55 ≤ -60 ≤ -60	@791.25MHz
RF return loss [dB]	≤ -18	f≤40MHz; f>40MHz: +1.5dB/oct
Test point @ input [dB]	-20 ± 1	Relative to the output of OFR receiver
Test points @ outputs [dB]	-20 ± 1	Directional coupler
Test points @ reverse inputs [dB]	-20 ± 1	Directional coupler
Number of RF ports/connectors type	3 / PG11	Port 1 – reverse auxiliary input 5 ÷ 210MHz for ORT transmitter
AC voltage range [V]	35 ÷ 65	AC 50÷60Hz
Maximum current for AC IN port [A]	15	Power insertion port
Maximum current for RF port [A]	12	All RF ports, except Port 1
AC current consumption [mA] 35VAC 48VAC 65VAC	1500 1150 850	RAG amplifier and OFR receiver
AC power consumption [W]	40 42	RAG amplifier and OFR receiver RAG amplifier, OFR receiver and ORT transmitter
Protection class IP	IP 67	
Operating ambient temperature range [°C]	-40 ÷ +60	
MTBF [years]	>30	@25°C, without ORT transmitter
Dimensions (W x L x H) [mm]	245 x 195 x 125	
Weight [kg]	4.3	

Specifications are subject to change without notice.

6.3. GAMMA O8X-11A-AE8

PARAMETER	VALUE	COMMENT
Wavelength [nm]	1100 ÷ 1600	
Optical input power range [dBm]	-5 ÷ +2	
Equivalent Input noise [pA/√Hz]	≤ 8	
Optical connector	SC/APC	Others on request
Optical power test point [V/mW]	1 ± 0.1	
RF level at the output of the OFR receiver [dBμV]	78 ± 1	4.5% OMI/channel, 0dBm input optical power
Optical Power Indicator [dBm]	- 5	Green – optical power > -5dBm Red – optical power < -5dBm
Forward bandwidth [MHz]	47...85 ÷ 862	DF duplex filters
Maximum output RF level [dBμV]	117 ± 1	0dBm input optical power, 4.5% OMI/channel
Flatness [dB]	± 0.75	DF duplex filters, AT 800 and ATG 800 jumpers
Slope [dB]	± 1	DF duplex filters, AT 800 and ATG 800 jumpers
CNR [dBc]	56	0dBm input optical power, 4.5%OMI/ channel, 10dB passive optical loss
Output level typ. [dBμV] CTB ≤ -60dBc CSO ≤ -60dBc	114 112	According to EN 50083-3; 9dB interstage equalizer, 42 CENELEC carriers, optical transmitter distortions not included
Reverse bandwidth [MHz]	5 ÷ 30...65	DF duplex filters
Reverse gain [dB]	26 ± 0.75	Port 4 to ORT reverse transmitter; DF duplex filters, ATG 800 jumpers, RCG 04 configuration module, RAG amplifier
Reverse noise figure [dB]	≤ 7	DF duplex filters, ATG 800 jumpers, RCG 04 configuration module and RAG amplifier
NPR [dBc]	≤ -60	RAG amplifier, 27dBμV/Hz signal @ 60MHz
HUM modulation @12A [dBc] 5÷15MHz 15÷65MHz 85÷862MHz	≤ -55 ≤ -60 ≤ -60	@791.25MHz
RF return loss [dB]	≤ -18	f≤40MHz; f>40MHz: +1.5dB/oct
Test point @ input [dB]	-20 ± 1	Relative to the output of OFR receiver
Test points @ outputs [dB]	-20 ± 1	Directional coupler
Test points @ reverse inputs [dB]	-20 ± 1	Directional coupler
Number of RF ports/connectors type	2 / PG11	Port 1 – reverse auxiliary input 5 ÷ 210MHz for ORT transmitter
AC voltage range [V]	35 ÷ 65	AC 50÷60Hz
Maximum current for AC IN port [A]	15	Power insertion port
Maximum current for RF port [A]	12	All RF ports, except Port 1
AC current consumption [mA] 35VAC 48VAC 65VAC	760 600 460	RAG amplifier and OFR receiver
AC power consumption [W] 22 23		RAG amplifier and OFR receiver RAG amplifier, OFR receiver and ORT transmitter
Protection class IP	IP 67	
Operating ambient temperature range [°C]	-40 ÷ +60	
MTBF [years]	>30	@25°C, without ORT transmitter
Dimensions (W x L x H) [mm]	245 x 195 x 125	
Weight [kg]	4.3	

Specifications are subject to change without notice.

7. PLUG-IN MODULES TECHNICAL SPECIFICATION

There is a wide range of additional plug-in modules available for broadband distribution node GAMMA allowing quick and simply configuration of the device and flexible matching the its functionality to individual requirements of the cable operator. Some of the plug-in modules are standardized elements also used in other amplifiers manufactured by VECTOR, while some of them are dedicated for broadband distribution node GAMMA exclusively.

This chapter covers the description and specification of all modules used for broadband distribution node GAMMA.

7.1. OFR 870-xxx – Optical receiver module

Optical receiver module **OFR 870-xxx** (xxx points the optical connector type, eg. SCA for SC/APC connector) is installed in a situation, when broadband distribution node GAMMA is configured as an optical receiver or optical node. The following table presents technical specification of the **OFR 870-SCA** module:

PARAMETER	VALUE	COMMENT
Wavelength [nm]	1100 ÷ 1600	
Optical input power range [dBm]	-5 ÷ +2	
Bandwidth [MHz]	47 ÷ 870	
Equivalent input noise $\left[\frac{pA}{\sqrt{Hz}} \right]$	≤ 8	
Optical connector	SC/APC	Others on request
Optical power test point [V/mW]	1 ± 0,1	
RF level at the output of the module [dBμV]	78 ± 1	4,5% OMI/channel, 0dBm input optical power
Optical Power Indicator [dBm]	-5	Green - optical power > -5dBm Red - optical power < -5dBm
RF test point - directional [dB]	-20	Relative to module output signal
Responsivity [A/W]	0.85	For 1310 nm
Responsivity [A/W]	0.98	For 1550 nm
CNR [dB]	56	0dBm optical input power, 4.5% OMI/channel, 10dB passive optical loss

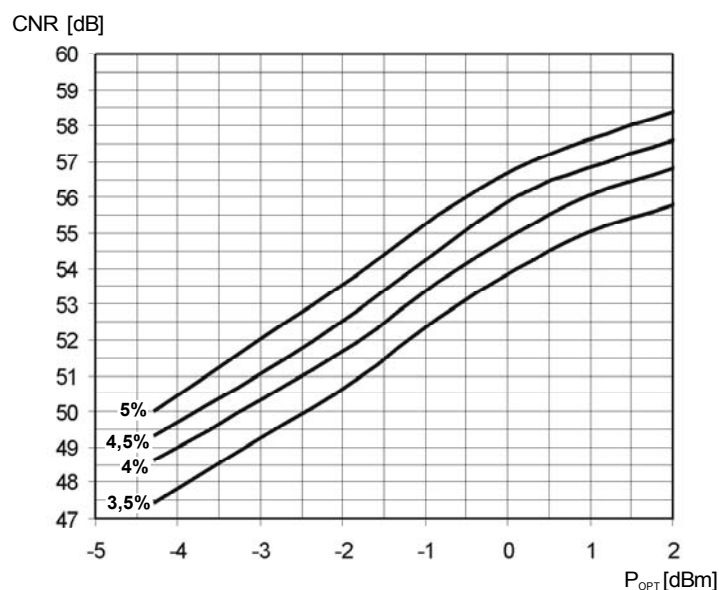

Fig. 19. CNR vs. optical input power and OMI/channel.

7.2. OSR 870-xxx –Optical receiver with redundancy module

Redundant optical receiver module **OSR 870-xxx** (xxx points the optical connector type, eg. SCA for SC/APC connector) is installed instead of the optical receiver module **OFR 870-xxx** in a situation, when redundancy for forward path is required. There is an A/B switch included in the module allowing to choose the optical link between the primary and redundant ones. The following table presents technical specification of the **OSR 870-SCA** module:

PARAMETER	VALUE	COMMENT
Wavelength [nm]	1100 ÷ 1600	
Optical input power range [dBm]	-5 ÷ +2	
Bandwidth [MHz]	47 ÷ 870	
Equivalent input noise $\left[\frac{pA}{\sqrt{Hz}} \right]$	≤ 8	
Optical connector	SC/APC	Others on request
Optical power test point [V/mW]	$1 \pm 0,1$	
RF level at the output of the module [dB μ V]	78 ± 1	4,5% OMI/channel, 0dBm input optical power
Optical Power Indicator [dBm]	-5	Green - optical power > -5dBm Red - optical power < -5dBm
RF test point - directional [dB]	-20	Relative to module output signal
Responsivity [A/W]	0.85	For 1310 nm
Responsivity [A/W]	0.98	For 1550 nm
CNR [dB]	56	0dBm optical input power, 4.5% OMI/channel, 10dB passive optical loss
Time hysteresis [s]	20 typical	For switching A->B, B->A

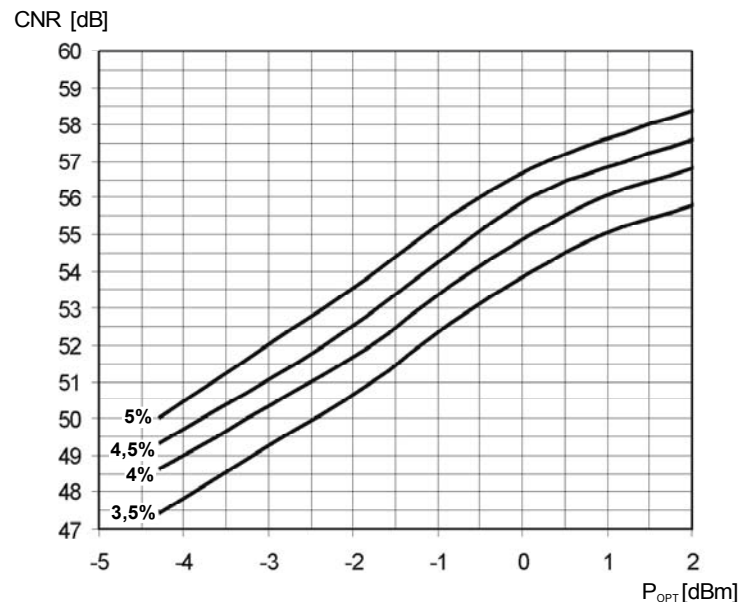

Fig. 20. CNR vs. optical input power and OMI/channel.

7.3. ORT F1310-xxx – FP 1310 nm optical transmitter module

Optical reverse transmitter module **ORT F1310-xxx** (xxx points the optical connector type, eg. SCA for SC/APC connector) is installed in a situation, when broadband distribution node GAMMA is configured as an optical node. Depending on the reverse path bandwidth we can distinguish 3 versions of the ORT F1310-SCA transmitter module. The following table presents technical specification of the **ORT F1310-SCA** module:

PARAMETER	VALUE	COMMENT
Laser type	FP non-isolated	
Wavelength [nm]	1310 ± 40	
Optical output power [dBm]	0 ± 1	
Bandwidth [MHz]		For internal RF input
<ul style="list-style-type: none"> • ORT F1310-SCA • ORT F1310-SCA/42/ • ORT F1310-SCA/30/ 	<ul style="list-style-type: none"> 5 ÷ 65 5 ÷ 42 5 ÷ 30 	
Minimum input level for NPR > 30dB [dBµV/Hz]		RF laser drive @ 25°C, 5dB optical loss:
<ul style="list-style-type: none"> • ORT F1310-SCA • ORT F1310-SCA/42/ • ORT F1310-SCA/30/ 	<ul style="list-style-type: none"> 6 8 9 	<ul style="list-style-type: none"> for 60MHz load for 37MHz load for 25MHz load
NPR > 30dB dynamic range [dB]	25	@ 25°C, 5dB optical loss
Optical connector	SC/APC	Others on request
Laser power status indicator [dBm]	-3	Green – optical power > -3dBm Red – optical power < -3dBm
RF test point - directional [dB]	-15	Relative to signal level at the laser diode
Insertion loss for internal RF input [dB]	5	For 0dB pad and OLP module input - port 1
Bandwidth [MHz]	5 ÷ 210	For external RF input - port 1
Insertion loss for external RF input [dB]	4	For 0dB pad
OMI variation over temperature [dB]	± 2	

NPR vs. RF level for FP laser (typical)

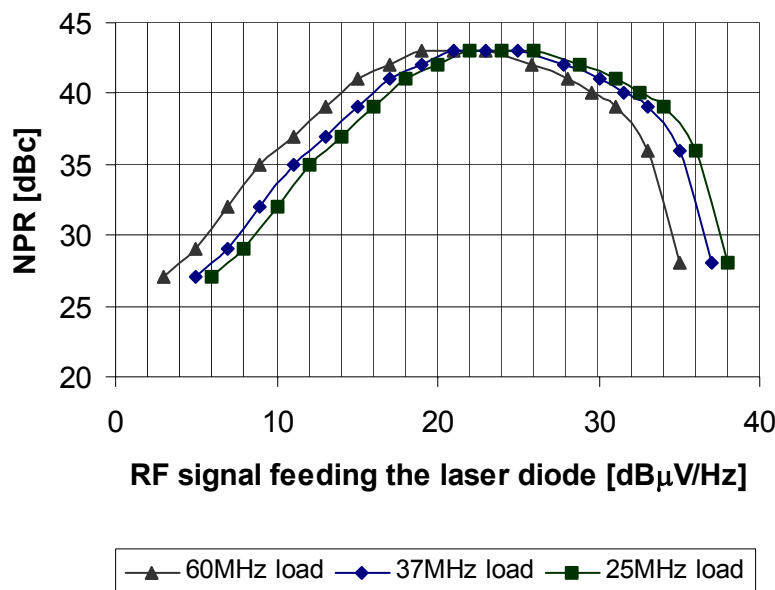

Fig. 21. NPR vs. RF level drive for optical reverse transmitter ORT F1310-xxx (typical).

7.4. ORT D1310-xxx – DFB 1310 nm optical transmitter module

Optical reverse transmitter module **ORT D1310-xxx** (xxx points the optical connector type, eg. SCA for SC/APC connector) is installed in a situation, when broadband distribution node GAMMA is configured as an optical node. Depending on the reverse path bandwidth we can distinguish 3 versions of the ORT D1310-SCA transmitter module. The following table presents technical specification of the **ORT D1310-SCA** module:

PARAMETER	VALUE	COMMENT
Laser type	DFB isolated	
Wavelength [nm]	1310 ± 40	
Optical output power [dBm]	0 ± 1	
Bandwidth [MHz]		For internal RF input
• ORT D1310-SCA	5 ÷ 65	
• ORT D1310-SCA/42/	5 ÷ 42	
• ORT D1310-SCA/30/	5 ÷ 30	
Minimum input level for NPR > 35dB [dBµV/Hz]		RF laser drive @ 25°C, 5dB optical loss:
• ORT D1310-SCA	1	for 60MHz load
• ORT D1310-SCA/42/	3	for 37MHz load
• ORT D1310-SCA/30/	4	for 25MHz load
NPR > 35dB dynamic range [dB]	25	@ 25°C, 5dB optical loss
Optical connector	SC/APC	Others on request
Laser power status indicator [dBm]	-3	Green – optical power > -3dBm Red – optical power < -3dBm
RF test point - directional [dB]	-15	Relative to signal level at the laser diode
Insertion loss for internal RF input [dB]	5	For 0dB pad and OLP module input - port 1
Bandwidth [MHz]	5 ÷ 210	For external RF input - port 1
Insertion loss for external RF input [dB]	4	For 0dB pad
OMI variation over temperature [dB]	± 2	

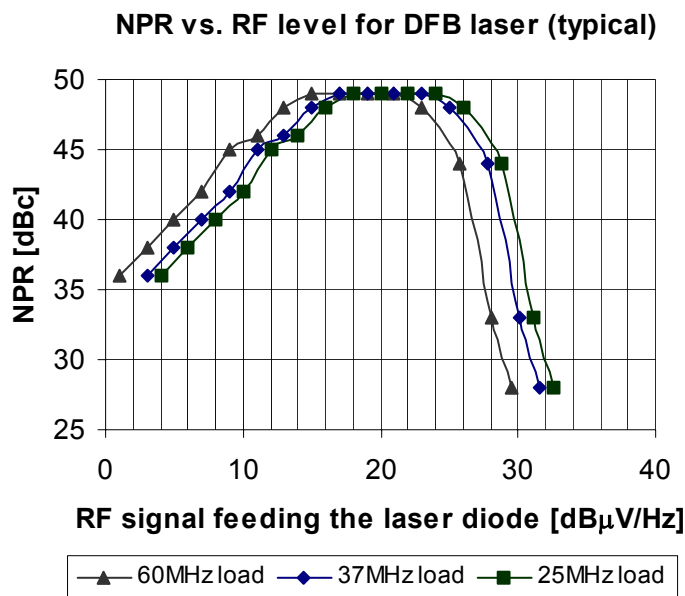

Fig. 22. NPR vs. RF level drive for optical reverse transmitter ORT D1310-xxx (typical).

7.5. ORT 3D1310-xxx – DFB 1310 nm optical transmitter module

Optical reverse transmitter module **ORT 3D1310-xxx** (xxx points the optical connector type, eg. SCA for SC/APC connector) is installed in a situation, when broadband distribution node GAMMA is configured as an optical node. Depending on the reverse path bandwidth we can distinguish 3 versions of the ORT 3D1310-SCA transmitter module. The following table presents technical specification of the **ORT 3D1310-SCA** module:

PARAMETER	VALUE	COMMENT
Laser type	DFB isolated	
Wavelength [nm]	1310 ± 20	
Optical output power [dBm]	3 ± 1	
Bandwidth [MHz]		For internal RF input
• ORT 3D1310-SCA	5 ÷ 65	
• ORT 3D1310-SCA/42/	5 ÷ 42	
• ORT 3D1310-SCA/30/	5 ÷ 30	
Minimum input level for NPR > 35dB [dBµV/Hz]		RF laser drive @ 25°C, 5dB optical loss:
• ORT 3D1310-SCA	0	for 60MHz load
• ORT 3D1310-SCA/42/	2	for 37MHz load
• ORT 3D1310-SCA/30/	3	for 25MHz load
NPR > 35dB dynamic range [dB]	>25	@ 25°C, 5dB optical loss
Optical connector	SC/APC	Others on request
Laser power status indicator [dBm]	0	Green – optical power > 0dBm Red – optical power < 0dBm
RF test point - directional [dB]	-15	Relative to signal level at the laser diode
Insertion loss for internal RF input [dB]	5	For 0dB pad and OLP module input - port 1
Bandwidth [MHz]	5 ÷ 210	For external RF input - port 1
Insertion loss for external RF input [dB]	4	For 0dB pad
OMI variation over temperature [dB]	± 2	

NPR vs. RF level for DFB laser (typical)

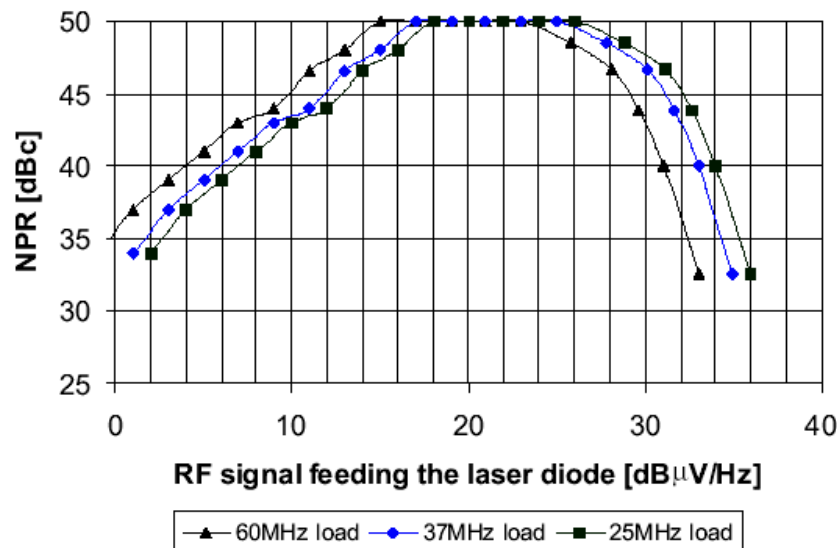

Fig. 23. NPR vs. RF level drive for optical reverse transmitter ORT 3D1310-xxx (typical).

7.6. ORT D1550-xxx – DFB 1550 nm optical transmitter module

Optical reverse transmitter module **ORT D1550-xxx** (xxx points the optical

connector type, eg. SCA for SC/APC connector) is installed in a situation, when broadband distribution node GAMMA is configured as an optical node. Depending on the reverse path bandwidth we can distinguish 3 versions of the ORT D1550-SCA transmitter module. The following table presents technical specification of the **ORT D1550-SCA** module:

PARAMETER	VALUE	COMMENT
Laser type	DFB isolated	
Wavelength [nm]	1550 ± 20	
Optical output power [dBm]	3 ± 1	
Bandwidth [MHz]		For internal RF input
<ul style="list-style-type: none"> • ORT D1550-SCA • ORT D1550-SCA/42/ • ORT D1550-SCA/30/ 	<ul style="list-style-type: none"> 5 ÷ 65 5 ÷ 42 5 ÷ 30 	
Minimum input level for NPR > 35dB [dBµV/Hz]		RF laser drive @ 25°C, 5dB optical loss:
<ul style="list-style-type: none"> • ORT D1550-SCA • ORT D1550-SCA/42/ • ORT D1550-SCA/30/ 	<ul style="list-style-type: none"> 1 3 4 	<ul style="list-style-type: none"> for 60MHz load for 37MHz load for 25MHz load
NPR > 35dB dynamic range [dB]	25	@ 25°C, 5dB optical loss
Optical connector	SC/APC	Others on request
Laser power status indicator [dBm]	0	Green – optical power > 0dBm Red – optical power < 0dBm
RF test point - directional [dB]	-15	Relative to signal level at the laser diode
Insertion loss for internal RF input [dB]	5	For 0dB pad and OLP module input - port 1
Bandwidth [MHz]	5 ÷ 210	For external RF input - port 1
Insertion loss for external RF input [dB]	4	For 0dB pad
OMI variation over temperature [dB]	± 2	

NPR vs. RF level for DFB laser (typical)

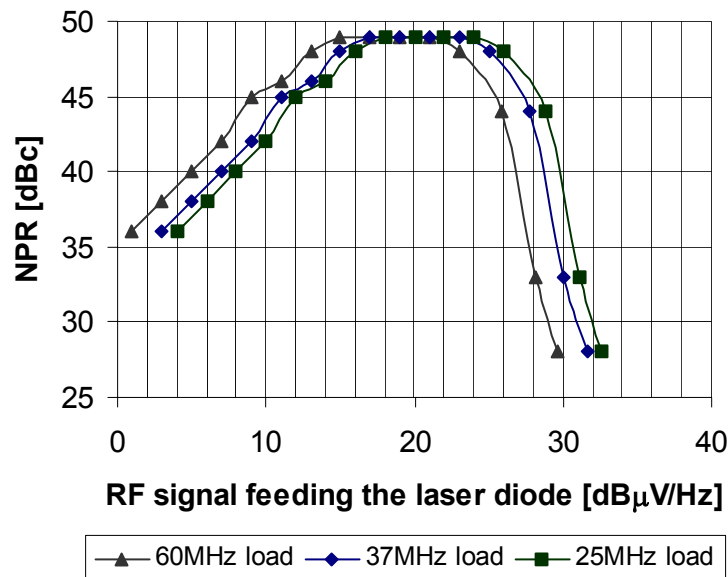

Fig. 24. NPR vs. RF level drive for optical reverse transmitter ORT D1310-xxx (typical).

7.7. ORT DCXXXX-xxx – DFB CWDM optical transmitter module

Optical reverse transmitter module **ORT DCXXXX-xxx** (XXXX points the CWDM wavelength = 1470, 1490, 1510, 1530, 1550, 1570, 1590, 1610; xxx points the optical connector type, eg. SCA for SC/APC connector) is installed in a situation, when broadband distribution node GAMMA is configured as an optical node. Depending on the reverse path bandwidth we can distinguish 3 versions of the ORT DCXXXX-SCA transmitter module. The following table presents technical specification of the **ORT DCXXXX-SCA** module:

PARAMETER	VALUE	COMMENT
Laser type	DFB isolated	
Wavelength [nm]	XXXX ± 3	Narrowband transmitter ±2nm available on request
Optical output power [dBm]	3 ± 1	
Bandwidth [MHz]		For internal RF input
• ORT DC1550-SCA	5 ÷ 65	
• ORT DC1550-SCA/42/	5 ÷ 42	
• ORT DC1550-SCA/30/	5 ÷ 30	
Minimum input level for NPR > 35dB [dBμV/Hz]		RF laser drive @ 25°C, 5dB optical loss:
• ORT DC1550-SCA	1	for 60MHz load
• ORT DC1550-SCA/42/	3	for 37MHz load
• ORT DC1550-SCA/30/	4	for 25MHz load
NPR > 35dB dynamic range [dB]	25	@ 25°C, 5dB optical loss
Optical connector	SC/APC	Others on request
Laser power status indicator [dBm]	0	Green – optical power > 0dBm Red – optical power < 0dBm
RF test point - directional [dB]	-15	Relative to signal level at the laser diode
Insertion loss for internal RF input [dB]	5	For 0dB pad and OLP module input - port 1
Bandwidth [MHz]	5 ÷ 210	For external RF input - port 1
Insertion loss for external RF input [dB]	4	For 0dB pad
OMI variation over temperature [dB]	± 2	

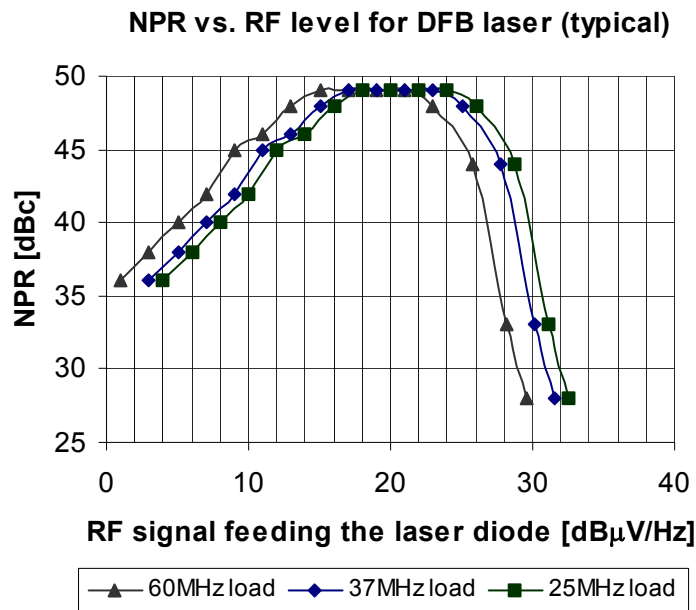

Fig. 25. NPR vs. RF level drive for optical reverse transmitter ORT D1310-xxx (typical).

7.8. AGC xxx-x – Automatic gain control module

Automatic gain control module **AGC xxx-x** can be used for broadband distribution node GAMMA working as a distribution amplifier as well as an optical receiver or optical node. Automatic gain control circuit is controlled by pilot tone level (xxx points the pilot frequency).

The module is designed for the forward bandwidth that is pointed by the last x.

Following modules are available:

AGC xxx-3 for 47MHz – 862MHz forward bandwidth

AGC xxx-4 for 54MHz – 862MHz forward bandwidth

AGC xxx-6 for 85MHz – 862MHz forward bandwidth

The following table presents technical specification of the **AGC xxx-x** module:

Bandwidth [MHz]	x ÷ 862
Pilot frequency [MHz]	xxx
Video carrier to pilot tone ratio [dB]	0 ÷ -12
3 dB bandwidth (minimum) [MHz]	4
20 dB bandwidth [MHz]	15
Dynamics [dB]	8
AGC insertion loss [dB]	3,5
Level stability over ± 4dB input change over temperature range – 40 ÷ +60°C [dB]	± 1

7.9. AGC 000-x – Automatic gain control module

Automatic gain control module **AGC 000-x** can be used for broadband distribution node GAMMA with OFR 870-xxx optical receiver installed, which means working as an optical receiver or optical node. Automatic gain control circuit is controlled by optical input power to the receiver. The module is designed for the forward bandwidth that is pointed by the last x. Following modules are available:

AGC 000-3 for 47MHz – 862MHz forward bandwidth

AGC 000-4 for 54MHz – 862MHz forward bandwidth

AGC 000-6 for 85MHz – 862MHz forward bandwidth

The following table presents technical specification of the **AGC 000-x** module:

Bandwidth [MHz]	x ÷ 862
Dynamics [dB]	8
Level stability over ± 2dBm input optical power change [dB]	± 1
AGC insertion loss [dB]	3,5

7.10. ASC 549-6 – Automatic slope and gain control module controlled by pilot tone

Automatic slope and gain control module **ASC 549-6** can be used for broadband distribution node GAMMA working as a distribution amplifier as well as an optical receiver or optical node. ASC circuit is controlled by pilot tone level @ 549 MHz.

Bandwidth [MHz]	85 ÷ 862
Pilot frequency [MHz]	549
0,5 dB bandwidth [MHz]	0,2
20 dB bandwidth [MHz]	2,8
Dynamics [dB]	
@862MHz	6
@549MHz	4,5
@85MHz	3
AGC insertion loss [dB]	3,5
Stability over ± 40°C temperature change [dB]	± 1

7.11. RCA – Output module for coaxial reverse output

Output module for coaxial reverse output **RCA** can be used for broadband distribution node GAMMA working as an optical receiver with coaxial reverse output. The following table presents technical specification of the **RCA** module:

Attenuation [dB]	2,3
Bandwidth [MHz]	5 ÷ 65
Max. AC current [A]	12
HUM [dBc]	< -60

Group delay in 1,5MHz bandwidth

Frequency range [MHz]	5 – 6,5	6,5 - 8	8 – 9,5	60,5 – 62	62 - 63,5	63,5 - 65
Group delay [ns]	87	49	20,5	1,1	2,4	2,5

7.12. CKG 01 – Optical node conversion kit

Optical node conversion kit CKG 01 allows quick and simply conversion from distribution amplifier to optical node. The CKG 01 kit includes:

- optical input adapter PG-16,
- plate,
- fiber holders,
- mounting screws.

7.13. RAG 29-1 xx – Reverse amplifier module for single reverse path

Reverse amplifier module for single reverse path **RAG 29-1 xx** allows amplification of the signal in reverse direction while using only single reverse path. **RAG 29-1 xx** module is installed in *REVERSE AMPLIFIER* socket. The following table presents technical specification of the **RAG 29-1 xx** module.

Maximum gain [dB]	29 ± 0,75
Bandwidth [MHz]	5 ÷ 30 ¹
	5 ÷ 42 ²
	5 ÷ 65 ³
Flatness [dB]	± 0,7
Noise figure for configuration module RCG 04 [dB]	≤ 6
NPR for 60 MHz load @ 27dBμV/Hz [dBc]	≤ -60
NPR for 37 MHz load @ 29dBμV/Hz [dBc]	≤ -60
NPR for 25 MHz load @ 30dBμV/Hz [dBc]	≤ -60
Third order beat IMD3 @ 110dBμV ⁴ [dBc]	≤ -60
Second order beat IMD2 @ 110dBμV ⁴ [dBc]	≤ -60
Power consumption [W]	1,2

¹ RAG 29-1 30

² RAG 29-1 42

³ RAG 29-1

⁴ EN 50083-3

Group delay

Frequency range [MHz]	5 – 6,5	6,5 – 8	8 – 9,5	60,5 – 62
Group delay [ns]	1,8	0,6	0,3	2,3

7.14. RAG 29-2 – Reverse amplifier module for dual reverse path

Reverse amplifier module for dual reverse path **RAG 29-2** allows amplification of the signals in reverse direction while using dual reverse path. **RAG 29-2** module is installed in *REVERSE AMPLIFIER* socket. The following table presents technical specification of the **RAG 29-2** module:

Maximum gain [dB]	$2 \times 29 \pm 0,75$
Bandwidth [MHz]	$5 \div 30$ ¹
	$5 \div 42$ ²
	$5 \div 65$ ³
Flatness [dB]	$\pm 0,7$
Noise figure for configuration module RCG 04 [dB]	≤ 6
NPR for 60 MHz load @ 27dB μ V/Hz [dBc]	≤ -60
NPR for 37 MHz load @ 29dB μ V/Hz [dBc]	≤ -60
NPR for 25 MHz load @ 30dB μ V/Hz [dBc]	≤ -60
Third order beat IMD3 @ 110dB μ V ⁴ [dBc]	≤ -60
Second order beat IMD2 @ 110dB μ V ⁴ [dBc]	≤ -60
Power consumption [W]	2,4

¹ RAG 29-2 30² RAG 29-2 42³ RAG 29-2⁴ EN 50083-3

Group delay

Frequency range [MHz]	5 – 6,5	6,5 – 8	8 – 9,5	60,5 – 62
Group delay [ns]	1,8	0,6	0,3	2,3

7.15. RCG xx – Reverse configuration modules

Reverse configuration modules **RCG xx** allows achieving required functionality of the broadband distribution node GAMMA for reverse path (redundancy or segmentation).

RCG xx module is installed in *REV.CONFIG.MODULE* socket. The following table presents technical specification of the **RCG xx** modules:

Module type	Port RF to ORT module gain (with RAG 29-x and diplex filter DF installed) [dB]	Port RF to ORT module attenuation (with diplex filter DF and jumpers RJP installed) [dB]
RCG 01	21	8
RCG 02	26 for REV 1	3 for REV 1
	23 for REV 2	6 for REV 2
RCG 03	23 for REV 1	6 for REV 1
	26 for REV 2	3 for REV 2
RCG 04	26	3
RCG 05	18	11
RCG 06	20	9
RCG 07	22	7

7.16. ISG 65 – Ingress switch module

Ingress switch module **ISG 65** is used in when interacting with Network Management System using NMS transponder. It allows ingress source detection by remote control of 3-state ingress switches insertion loss 0 / 6 / OFF. There is no need to plug any additional modules, while ingress switch module is not installed - autolink circuit provides connectivity automatically. The following table presents technical specification of the **ISG 65** module:

State	Attenuation [dB]
0 dB	0.5
6 dB	6 ± 0.5
OFF	> 30

7.17. OLP xx – Band-pass filter module for optical reverse transmitter

Band-pass filter module **OLP xx** (xx points the cut-off frequency) is factory installed inside the **ORT x1310-xxx** optical reverse transmitter module. The following table presents technical specification of the **OLP 65** module:

Insertion loss [dB]	-1 +0.5/-1
Stop band rejection [dB]	> 30

Group delay in 1.5MHz bandwidth

Frequency range [MHz]	5 – 6.5	6.5 - 8	8 – 9.5	60.5 – 62	62 - 63.5	63.5 – 65
Group delay [ns]	64	32	15	1.9	1.7	1.2

Band-pass filter module **OLP xx** (xx points the cut-off frequency) is factory installed inside the optical reverse transmitter module **ORT**. Depending on the reverse path bandwidth we can distinguish 3 versions of the OLP xx module. The following table presents technical specification of the **OLP 65** module:

Insertion loss [dB]	-1 +0.5/-1
Stop band rejection [dB]	> 30

Group delay in 1.5MHz bandwidth

Frequency range [MHz]	5 – 6.5	6.5 - 8	8 – 9.5	60.5 – 62	62 - 63.5	63.5 - 65
Group delay [ns]	64	32	15	1.9	1.7	1.2

7.18. OLPA xx – Active band-pass filter module for optical reverse transmitter

Active band-pass filter module **OLPA xx** (xx points the cut-off frequency) is installed instead of **OLP xx** module in a situation when additional amplification of reverse path is required. OLPA 30, OLPA 42, OLPA 65 module versions are available. The following table presents technical specification of the **OLPA 65** module:

Gain [dB]	20 ± 1
Stop band rejection [dB]	> 30

Group delay in 1.5MHz bandwidth

Frequency range [MHz]	5 – 6.5	6.5 - 8	8 – 9.5	60.5 – 62	62 - 63.5	63.5 - 65
Group delay [ns]	64	32	15	1.9	1.7	1.2

7.19. HPG xx – High-pass filter module

High-pass filter module HPG xx is used in a situation, when automatic gain control module AGC is not used. **HPG xx** module (xx points the cut-off frequency) is factory mounted. HPG 30, HPG 42, HPG 65 module versions are available.

7.20. DF xxA – Diplex filter module

Diplex filter module **DF xxA** is used in a situation when broadband distribution node GAMMA is working in bi-directional HFC access networks in order to separate the forward and reverse path. **DF xxA** module (xx points the maximum frequency in reverse path) can be installed in *DIPLEX FILTER x* socket (x = 1, 2, 3 or 4). DF 30A, DF 42A and DF 65A filters versions are available.
DF 42A module specification.

Attenuation [dB] @ 5MHz	0.7
Attenuation [dB] @ 42MHz	1.5
Attenuation [dB] @ 54MHz	1.2
Attenuation [dB] @ 862MHz	0.5
Flatness [dB]	±0.4
Stop band rejection [dB]	45

Group delay in 1.5MHz bandwidth (reverse path)

Frequency range [MHz]	5 – 38	36 – 39	39 – 40.5	40.5 – 42
Group delay(Δ1.5MHz)[ns]	5	10	14	25

Group delay in 4.43MHz bandwidth (for forward path)

Frequency range [MHz]	54 – 60	60 – 75	75 – 862
Group delay (Δ4.43MHz)[ns]	14	6	3

The following table presents technical specification of the **DF 65A** module:

Attenuation [dB] @ 5MHz	0,3
Attenuation [dB] @ 65MHz	1
Attenuation [dB] @ 85MHz	1
Attenuation [dB] @ 862MHz	0,5
Flatness [dB]	±0,3
Stop band rejection [dB]	49

Group delay in 1,5MHz bandwidth

Frequency range [MHz]	5 – 6,5	6,5 – 8	8 – 9,5	60,5 – 62	62 - 63,5	63,5 - 65
Group delay [ns]	1	0,5	0,1	3,5	3,6	5,1

Group delay in 4,43MHz bandwidth (for forward path)

Frequency range [MHz]	85 – 89,43	89,43 – 93,86	93,86 – 98,29	98,29 – 102,72	102,72 – 107,15
Group delay [ns]	24	11	8	6	2

7.21. EQ 8xx – Fixed equalizer module for forward path

Fixed equalizer module **EQ 8xx** (xx points the tilt in dB) is used in order to adjust to required tilt of the signals in forward path both at the input and at the interstage of the amplifier, available range 1 ÷ 24dB with 1dB step. **EQ 8xx** module can be installed in *FWD EQ x* sockets (x=1, 2, 3 or 4). The following table presents technical specification of the **EQ 8xx** module:

Type	Freq. Range	Flatness @ slope
EQ 801 – EQ 808	47 – 862 MHz	±0.3
EQ 809 –EQ 822	47 – 862 MHz	±0.4
EQ 823, EQ 824	47 – 862 MHz	±0.8

Attention: xx symbols correspond to attenuation at 47 MHz
Example: EQ806 – Equalizer 6dB, 47- 862 MHz

7.22. EQSG 805 ÷ EQSG 811 – Forward path fixed system equalizer module for optimizing the characteristic of cascaded GAMMA

Forward path fixed system equalizer module for optimizing the characteristic of cascaded GAMMA. Installed at the input or interstage equalizer socket allows to improve flatness of the frequency response to +1,5dB. Equalization range 5 ÷ 11dB with step 1 dB.

7.23. CS 8xx – Cable simulator module

Cable simulator module **CS 8xx** is used instead of input equalization module **EQ 8xx** in forward path in situation when there is a negative tilted characteristic of the input RF signal. Such a situation can take place when using relative high interstage equalization while having relatively short distances between distribution amplifiers. **CS 8xx** module (xx points the tile in dB) can be installed in *FWD EQ 1* socket. The following table presents technical specification of the **CS 8xx** module:

Type	Freq. Range	Attenuation at upper frequency	Flatness @ slope
CS 80x	47 – 862 MHz	3 / 6 dB	±0.3

Attention: x symbol corresponds to attenuation at high frequency

Example: CS806 – Cable simulator 6dB for bandwidth 862 MHz

7.24. AT 800 – Jumper for forward path

AT 800 module is used instead of **EQ 8xx** modules (when no tilt is required) and instead of **DF 65A** modules (when no reverse path is used). In this connection **AT 800** module can be installed in *FWD EQ x* or *DIPLEX FILTER x* sockets (x = 1, 2, 3 or 4).

7.25. ATG 8xx/ATG 075 – Fixed attenuator and 75 Ohm terminator modules

ATG 8xx modules are used to attenuate the signal in forward and reverse path (xx points attenuation in dB), available range 0 ÷ 20dB with 1dB step. **ATG 075** module is 75Ohm terminator which can be put instead **ATG 8xx** attenuators. **ATG 8xx** modules can be installed in *FWD PAD x* (x=1, 2, 3 or 4), *REV PAD x* (x = 2, 3, 4 or 5) or *REV EQ PAD* sockets.

7.26. REQ xx – Equalizer module for reverse path

Equalizer module for reverse path **REQ xx** allows achieving required tilt of the reverse signal in a situation, when broadband distribution node GAMMA is working as distribution amplifier or optical receiver with coaxial reverse output. **REQ xx** module (xx points maximum frequency of reverse path) can be installed in *REQ* socket in *RCA* or *IBG* modules. **REQ xx** module defines the maximum frequency of the equalizer while attenuator **ATG 8xx** attenuator installed in *REV EQ PAD* socket defines the tilt.

7.27. RJP – Jumper for reverse path

RJP module is used instead of reverse amplifier module for passive reverse path as well as instead high-pass filters **RHP xx** for reverse path. **RJP** module can be installed in *REV FILTER 1*, *REV FILTER 2* or/and *REVERSE AMPLIFIER* sockets.

7.28. RHP xx – High-pass filter module for reverse path

High-pass filter module **RHP xx** can be used in order to attenuate undesirable interferences ingressing the access network in the low region of reverse bandwidth. **RHP xx** module (xx points the cut-off frequency) can be installed in *REVERSE FILTER 1* or/and *REVERSE FILTER 2* sockets. The following table presents technical specification of the **RHP 15** module:

Insertion loss @ 15MHz [dB]	2,2
Insertion loss @ 65MHz [dB]	1
Stop-band rejection [dB]	42

7.29. RRG xxx – Single tone reference generator module

Single tone reference generator module **RRG xxx** (xxx points the frequency of the tone) can be installed inside the optical reverse transmitter module ORT in order to generate the reference single tone signal. The following table presents technical specification of the **RRG 358** module:

Frequency [MHz]	3,579
Frequency stability over temperature	$5,6 \cdot 10^{-4}$
Harmonics [dBc]	< -25
OMI range [%]	0,8 – 3

7.30. PSG 65 – Switch mode power supply (SMPS) module 35÷65 VAC

7.31. PSG 90 – Switch mode power supply (SMPS) module 40÷90 VAC

APPENDIX 1. CHANGING THE BANDWIDTH OF GAMMA OPTICAL NODE.

Depending on customer's requirements, modular design of GAMMA optical node allows to change the bandwidth of the forward and reverse path. It is achieved by using the appropriate plug-in modules. Depending on installed modules, the bandwidth can be defined as follows:

Reverse path bandwidth [MHz]	Forward path bandwidth [MHz]
5 ÷ 30	47 ÷ 862
5 ÷ 42	54 ÷ 862
5 ÷ 65	85 ÷ 862

The following modules affect forward path bandwidth of Gamma optical node:

- HPG xx filter – factory installed module, if the node is not equipped with a AGC module;
- AGC xxx-x or AGC 000-x module.

The following modules affect reverse path bandwidth of Gamma optical node:

- DF xxA module (xx points the maximum frequency in reverse path) can be installed in *DIPLEX FILTER x* (x = 1,2,3 or 4) sockets;
- RAG 29-1 xx, RAG 29-2 xx reverse path amplifier:

Bandwidth [MHz]	Reverse path amplifier number
5 ÷ 30	RAG 29-1 30 or RAG 29-2 30
5 ÷ 42	RAG 29-1 42 or RAG 29-2 42
5 ÷ 65	RAG 29-1 or RAG 29-2

- OLP xx or OLPA xx module installed inside the optical transmitter housing.

While changing the bandwidth of reverse/forward path one should remember to replace all the mentioned above modules by the proper ones. Replacing only some of those modules may cause incorrect node functioning.

In order to change the reverse/forward path in GAMMA optical node one should comply with the following procedure:

1. Check if diplex filters installed in *DIPLEX FILTER x* (x-1,2,3 or 4) sockets are of the correct division frequency. If not, they should be replaced with correct ones.
2. If the amplifier is to be equipped with an optional automatic gain control module, install the appropriate AGC xxx-x or AGC 000-x module, according to the Fig. 10. If not, the installed HGP xx module should be replaced with a HGP xx module of required frequency (as shown on the Fig. 26) by following the procedure:
 - Unscrew AGC masking frame;
 - Take out HPG xx module;
 - Replace it with a new module with a proper cut-off frequency;
 - Screw down the AGC masking frame.
3. Replace RAG 29-1 xx (RAG 29-2 xx) amplifier module with a new one of required frequency.
4. Replace OLP xx module installed inside the optical transmitter (as shown on the Fig. 16) or replace the complete optical transmitter module.

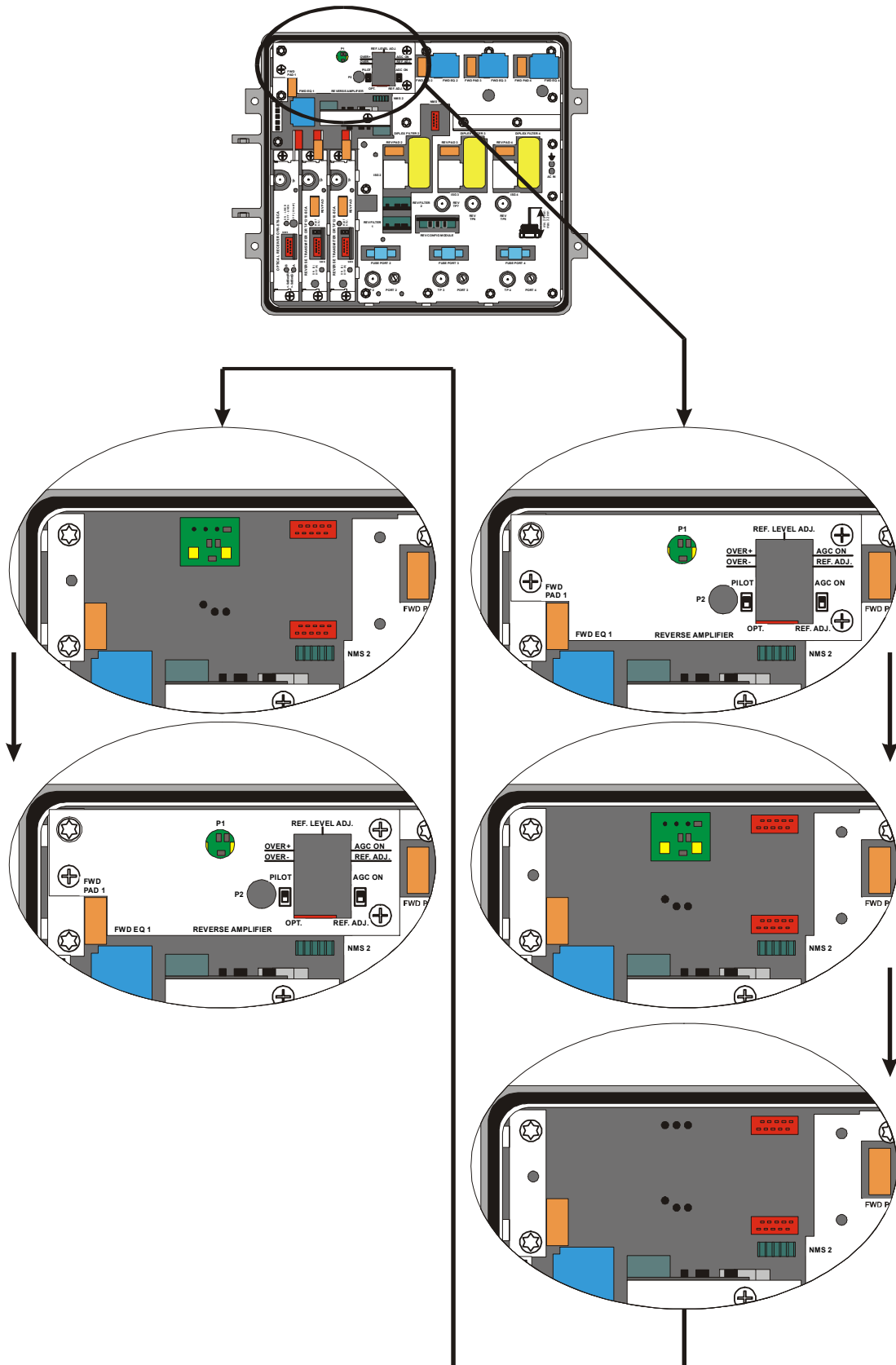

Fig. 26. HPG module replacement.

APPENDIX 2. OPTICAL ADAPTERS REPLACEMENT

Before replacement of SC-APC/ SC-APC adapters with SC-APC/E-2000 adapters one need to check if the masking frame for optical connectors allows the E-2000 adapters installation. Those adapters can be mounted only in the chassis with tapped holes (SC/SC adapters are mounted using springy plates and do not require those holes). If there are no such holes, you have to order the proper version of the masking module.

In order to replace the SC-APC/ SC-APC adapters with SC-APC/E-2000 adapters one should comply with the following procedure:

1. Detach pigtails from adapters;
2. By pressing the springy plates that hold the adapter in the chassis (plates are marked with arrows on Fig. 27), take out the adapter from the chassis;
3. Put the SC-APC/E-2000 adapter into the chassis and mount it with provided screws, as shown on Fig. 27;
4. Connect the pigtails to adapters, according to a description on the masking frame.

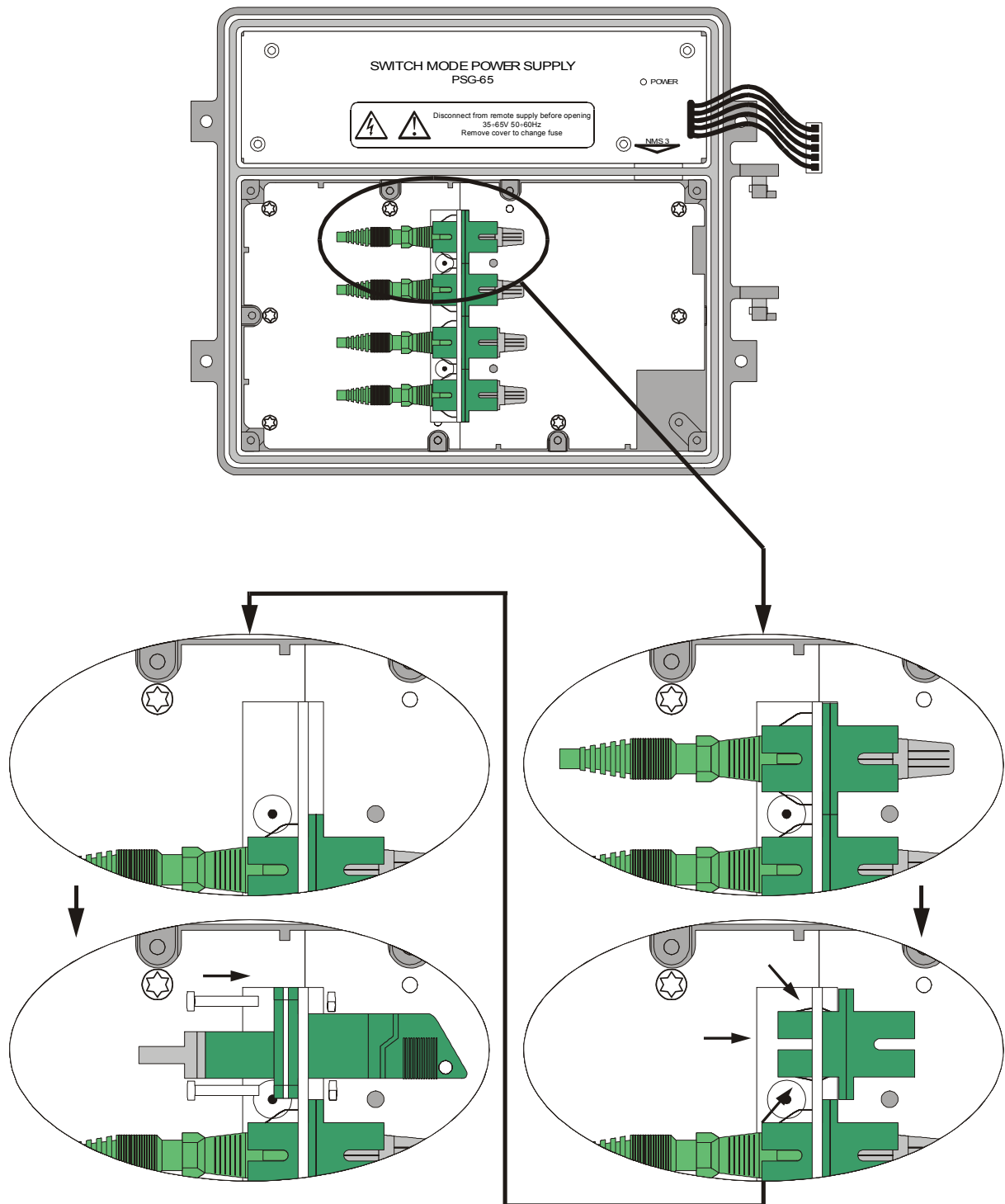

Fig. 27. Replacing the SC-APC/ SC-APC adapters with SC-APC/E-2000 adapters.